



# EBLING BACK BLADE

SERVICE SCHOOL

MECHANICS GUIDE





## **2025 BACK BLADE Mechanics Guide**

<b><u>Section</u></b>	<b><u>Page</u></b>
<b>Index Page</b>	1
<b>Installation Tips</b>	2
<b>BACK BLADE Adjustments</b>	
Hydraulic & Fixed Wing	3-5
sidekick	6
Tractor	7
<b>QD Arm Adjustments</b>	8-9
<b>Schematics</b>	
HW & FW Hydraulic Circuits	10-31
HW & FW Electrical	32-48
sidekick - All	49-52
<b>Troubleshooting Guides</b>	53
Hydraulic & Fixed Wing	54-56
sidekick	57-58
Tractor	59
<b>2012 &amp; Prior vs 2013+ Wiring</b>	60-63
<b>DPDT to SPDT Switches</b>	64-66
<b>Shear Bolt Information</b>	67-68
<b>Contacts &amp; Reference</b>	69
<b>Installation Checklists</b>	70-74



## Backblade Installation Tips

- 1 By attaching the red wire with fuse under the hood to circuit breaker battery side is useful in diagnosing issues, (i.e. This allows the controller to have power if there is a problem such as tripped circuit breaker or bad solenoid)
- 2 Make sure frame ground at rear of truck is ground clean and has a good connection. Ground directly to truck frame not to cross member. Many pump problems are caused by a weak or bad ground
- 3 When filling pump reservoir for the first time, start with 1 qt, adding only when empty. Never top off reservoir with blade down and wings closed. **Top off fluid with the blade fully in the raised position, and wings fully open for HW. (after cycling each function at least once)**
- 4 Taping red power cable and controller harness together, also removing in-line fuses to be reattached later will ease in routing the harness bundle from rear of truck forward. (make sure to route through switch plate first if one is being used, to avoid having to disassemble plug)
- 5 On some trucks it makes it easier to split the red power cable away from the harness on the plug end about 12" sooner than factory built. This is being changed on all new harnesses. (be sure to tape all harness wrap and any exposed wires after making changes to harness)
- 6 When adjusting wing cylinders for 90 degrees, take pressure off wing when removing clevis pin for adjustment. **(make sure cyl jam nuts are against adjusting end not against the cyl body, cyl damage will occur if incorrect)**



## Truck BACK BLADE Adjustments

1. Front-To-Back Alignment – The upper linkage arm adjustment is preset at the factory to provide the proper amount of upward angle on the wing cutting edges that will offset the friction force that will work to align the blade once the cutting edges contact the pavement and the blade moves forward. Depending on the plowing application, site conditions, and operator plowing methods, over the life of the cutting edges the upper arms may need to be adjusted periodically to provide more even wear of the wing cutting edges. If you observe the front surfaces of the wing cutting edges to be “rounding off” or wearing more rapidly than the rest of the cutting edge, then the upper arms need to be adjusted to compensate for the uneven wear. To adjust the upper arms:
  - With the blade in the fully raised position, observe the angle of the wing cutting edge bottom surfaces to determine the approximate amount and direction of correction needed.
  - Lower the blade to the ground using the remote RAISE/LOWER switch.
  - Loosen the jam nuts on the two upper linkage arms (see Figure 13).

Figure 13  
Upper Linkage Arm Jam Nut &  
Adjustable Clevis

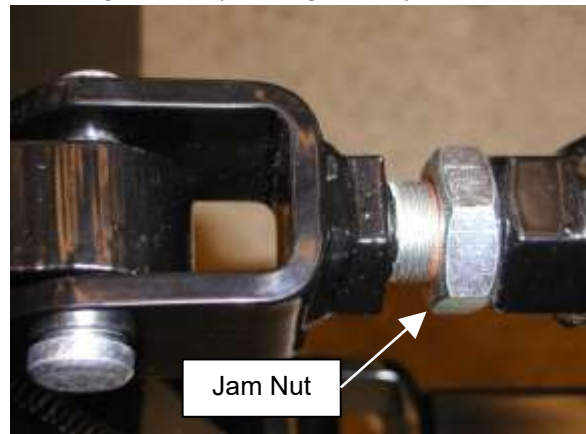

- For each upper arm, remove the clevis pin attaching the clevis to the QD frame, then turn the clevis end  $\frac{1}{2}$  turn in the direction of correction – see note below. (A full turn goes a long way, but may be needed in some cases.)

**NOTE:** If the wing cutting edge leading corners are too low, turn the adjustable clevis out to make the upper linkage arm longer. If the wing cutting edge leading corners are too high, turn the adjustable clevis in to make the upper linkage arm shorter.

- Replace the clevis pin and re-insert the cotter pin.
- Repeat the adjustment for the other upper linkage arm.



- Raise and lower the back blade a few times, re-check the level, and re-adjust, if necessary, until the desired alignment is achieved.
  - Tighten the jam nut on both upper linkage arms.
2. Side-To-Side Alignment – The moldboard cutting edge should be roughly parallel to the rear of the truck in order to obtain the most even cutting edge wear. If the back blade is observed to be out of alignment with the truck, most of the time this can be corrected by making the adjustment below:
- With the blade in the fully raised position, determine the approximate amount and direction of correction needed.
  - Loosen the four spring stabilizer bar mounting bolts (see Figure 14).

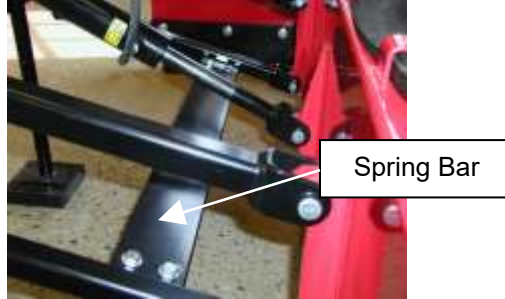

Figure 14  
Spring Bar Location

- Press down on the side of the back blade that is too high until the back blade is “pre-loaded” past level the other way to allow for some spring-back.
- While holding the back blade in this position, re-tighten the spring bar mounting bolts (an assistant may be required to help with this).
- Release the “pre-load” to let the spring bar stabilize the blade in the new position, and then check the alignment again.
- Re-adjust if necessary with more or less “pre-load” for the degree of correction needed, and then re-check alignment.

**NOTE:** If proper side-to-side alignment cannot be achieved after attempting this adjustment, please contact Ebling Snowplows for servicing or replacement instructions.

3. Adjustment can also be made to the wing cylinders. With wings fully closed check if the wing is 90 degrees to the moldboard. If not, open the wing slightly and remove the clevis pin on the moldboard side of the cylinder. Loosen the jam nut and turn the threaded end of the cylinder counterclockwise to make the wing close more or clockwise to make the wing close less. Make adjustments in half turn increments until a true 90 is achieved



when wing is fully closed. At 90 the rubber bumper will compress slightly. Open wing slightly and make sure cylinder hoses are straight up, replace clevis pin and cotter pin. Tighten cylinder jam nut. Check periodically to make sure wings stay in their 90 degree position.



## sidekick Adjustments

1. Front-To-Back Alignment – The upper linkage arm adjustment is set at the time of installation to provide the proper amount of upward angle on the wing cutting edges that will offset the friction force that will work to align the blade once the cutting edges contact the pavement and the blade moves forward. Depending on the plowing application, site conditions, and operator plowing methods, over the life of the cutting edges the upper arms may need to be adjusted periodically to provide more even wear of the wing cutting edges. If you observe the front surfaces of the wing cutting edges to be “rounding off” or wearing more rapidly than the rest of the cutting edge, then the upper arms need to be adjusted to compensate for the uneven wear. To adjust the upper arms:
  - With the blade in the fully lowered position, observe the angle of the wing cutting edge bottom surfaces to determine the approximate amount and direction of correction needed.
  - Take any pressure off the lowered blade.

Figure 8  
Upper Linkage Arm With Toothed Washer



- For each arm, loosen the arm bolt and the toothed washer, then adjust the arm length as needed by repositioning the toothed washer with the corresponding position and the upper arm.

**NOTE:** If the wing cutting edge leading corners are too low, lengthen the arms. If the wing cutting edge leading corners are too high, shorten the arms.

- Reposition the toothed washer and snug up bolt to hold it in the desired place.
- Adjusting both arms at the same timeworks best.
- Raise and lower the back blade a few times, re-check the level, and re-adjust, if necessary, until the desired alignment is achieved.
- Tighten the arm bolt on both sides.



## **Tractor BACK BLADE Adjustments**

1. **Front-To-Back Alignment** – The top link arm provides the proper amount of upward angle on the wing cutting edges that will offset the friction force that will work to align the blade once the cutting edges contact the pavement and the blade moves forward. Depending on the plowing application, site conditions, and operator plowing methods, over the life of the cutting edges the upper arm may need to be adjusted periodically to provide more even wear of the wing cutting edges. If you observe the front surfaces of the wing cutting edges to be “rounding off” or wearing more rapidly than the rest of the cutting edge, then the top link needs to be adjusted to compensate for the uneven wear.
2. Adjustment can also be made to the wing cylinders. With wings fully closed check if the wing is 90 degrees to the moldboard. If not, open the wing slightly and remove the clevis pin on the moldboard side of the cylinder. Loosen the jam nut and turn the threaded end of the cylinder counterclockwise to make the wing close more or counter clockwise to make the wing close less. Make adjustments in half turn increments until a true 90 is achieved when wing is fully closed. At 90 the rubber bumper will compress slightly. Open wing slightly and make sure cylinder hoses are straight up, replace clevis pin and cotter pin. Tighten cylinder jam nut. Check periodically to make sure wings stay in their 90 degree position.



## Truck Mount Fit Guide

The Following Truck Mounts Are Approved By Ebling For The Model,  
Year, Make And Frame Style Shown. Any Back Blade Installed On A  
Custom Or Modified Mount May Void Warranty

### Truck Mount/QD Arm Settings

Mount	Vehicle (1)	Vehicle Rating	Arm Length	Arm Position	Arm Flat Edge	Inside Arm Width	QD w/ Single Hex Plate Spacer (3)
1A (4)	Dodge 03-10 Long Box	3/4 or 1 Ton	25 1/4"	Inside	Down	37"	5/16" & 1/2"
1B (4)	Dodge 03-10 Short Box	3/4 or 1 Ton	25 1/4"	Inside	Down	37"	5/16" & 1/2"
1J (2)(4)(5)	Dodge 11-Current 2500/11-18 3500	3/4 or 1 Ton*	23 1/4"	Inside	Up (2)	37"	5/16" & 1/2"
1K (2)(4)(5)	Dodge 11-Current 2500/11-18 3500 & 19-Current 3500 (Supercedes 1J Mount)	3/4 or 1 Ton*	23 1/4"	Inside	Up (2)	37"	5/16" & 1/2"
2A	Ford 99-07 All	3/4 or 1 Ton	25 1/4"	Inside	Down	38"	5/16"
2B	Ford 08-16 All	3/4 or 1 Ton	23 1/4"	Inside	Down	38"	5/16"
2M (2)	Ford 17-22 All - 2" Receiver	3/4 or 1 Ton	23 1/4"	Outside	Up (2)	42 1/4"	5/16"
2N (2)	Ford 17-22 All - 2 1/2" Receiver	3/4 or 1 Ton	23 1/4"	Outside	Up (2)	42 1/4"	5/16"
2O (2)	Ford 23-All - 2" Receiver	3/4 or 1 Ton	23 1/4"	Outside	Up (2)	42 1/4"	5/16"
2P (2)	Ford 23-All - 2 1/2" Receiver	3/4 or 1 Ton	23 1/4"	Outside	Up (2)	42 1/4"	5/16"
3A	GM 01-07 Long Box Classic	3/4 or 1 Ton	23 1/4"	Outside	Down	42 1/4"	5/16"
3B	GM 01-07 Short Box Classic	3/4 or 1 Ton	23 1/4"	Outside	Down	42 1/4"	5/16"
3C	GM 07.5-10 Long Box	3/4 or 1 Ton	23 1/4"	Outside	Down	42 1/4"	5/16"
3D	GM 07.5-10 Short Box	3/4 or 1 Ton	23 1/4"	Outside	Down	42 1/4"	5/16"
3L	GM 11-14 Long Box	3/4 or 1 Ton	23 1/4"	Outside	Down	42 1/4"	5/16"
3M	GM 11-14 Short Box	3/4 or 1 Ton	23 1/4"	Outside	Down	42 1/4"	5/16"
3O	GM 15-19 Long Box	3/4 or 1 Ton	23 1/4"	Inside	Down	36 3/4"	5/16" & 5/8"
3R	GM 15-19 Short Box	3/4 or 1 Ton	23 1/4"	Inside	Down	36 3/4"	5/16" & 5/8"
3W (4)	GM 20-21 All - Discontinued	3/4 or 1 Ton	23 1/4"	Inside	Down	36 3/4"	5/16" & 5/8"
3X (4)	GM 20-21 All - Discontinued	3/4 or 1 Ton	23 1/4"	Inside	Down	36 3/4"	5/16" & 5/8"
3Y (4)	GM 20-Current All (Supercedes 3X Mount)	3/4 or 1 Ton	23 1/4"	Inside	Down	36 3/4"	5/16" & 5/8"
CC(6)	All Cab & Chassis Applications	N/A(6)	25 1/4"	Inside	N/A(6)	N/A(6)	N/A(6)

(1) NOTE - ALL FRAMES MUST BE PICK UP BOX FRAMES OR BOX DELETE - CAB & CHASSIS NOT STANDARD DUALY, CAB & CHASSIS AND FLATBED TRUCKS MAY BE COMPATABLE WITH THE EBLING BACK BLADE. CONTACT EBLING FOR ADDITIONAL INFORMATION.

(2) NOTE - 17-CURRENT FORD 2M MOUNTS, 2018-CURRENT DODGE 1F & 1J & 2019-Dodge 3500 1K MOUNTS MUST BE INSTALLED WITH FLAT SIDE OF ARM UP FOR TAILGATE CLEARANCE.

(3) NOTE - ALL OLD STYLE (-2015) QDS W/ DOUBLE HEX PLATES DO NOT REQUIRE THE 5/16" SPACER PLATES. THESE QDS MUST USE BEVELED EDGED ARMS TO CLEAR WELDS. CONTACT EBLING FOR ADDITIONAL INFORMATION.

(4) NOTE - ALL DODGE AND 2020 GM BACK BLADE MOUNTS ARE USED IN CONJUNCTION WITH THE OEM RECEIVER HITCH. EBLING V-5 HITCH NOT INCLUDED ON DODGE OR 2020 GM MOUNTS

(5) NOTE - ALL DODGES WITH REAR BUMPER LOWER PLASTIC FASCIA MUST REMOVE OR TRIM FOR MOUNT CLEARANCE

(6) NOTE - ALL CAB & CHASSIS MOUNTS ARE A CUSTOM SITUATION AND ARMS/SPACER PLATES WILL BE MOUNTED IN ACCORDANCE WITH DESIGN AND CAB & CHASSIS CUSTOM QD CHANNEL



## Follow Directions For Your Particular Mount On The Truck Mount Fit Guide

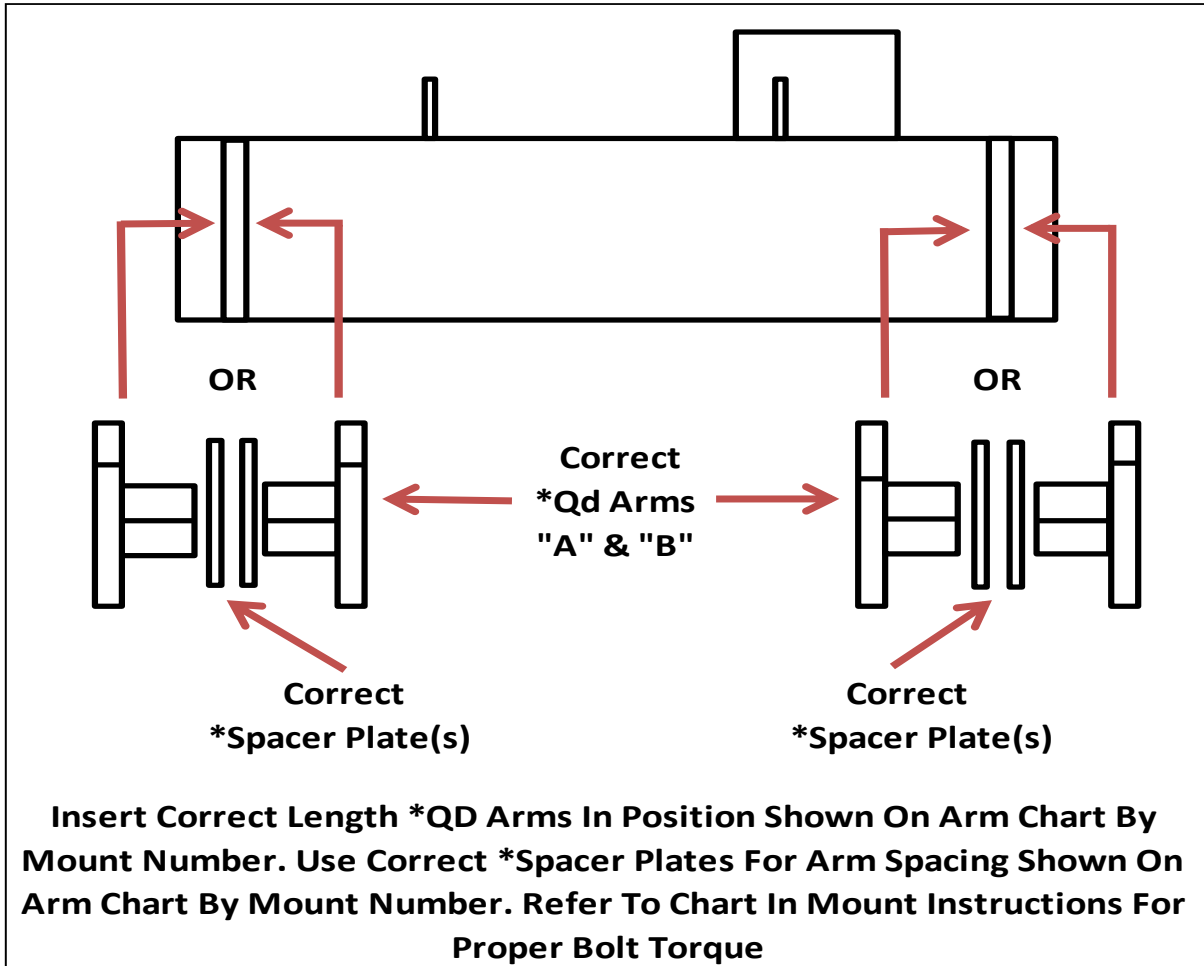

Flat Edge Of QD Arm



## Exploded View Of Common Valve Design

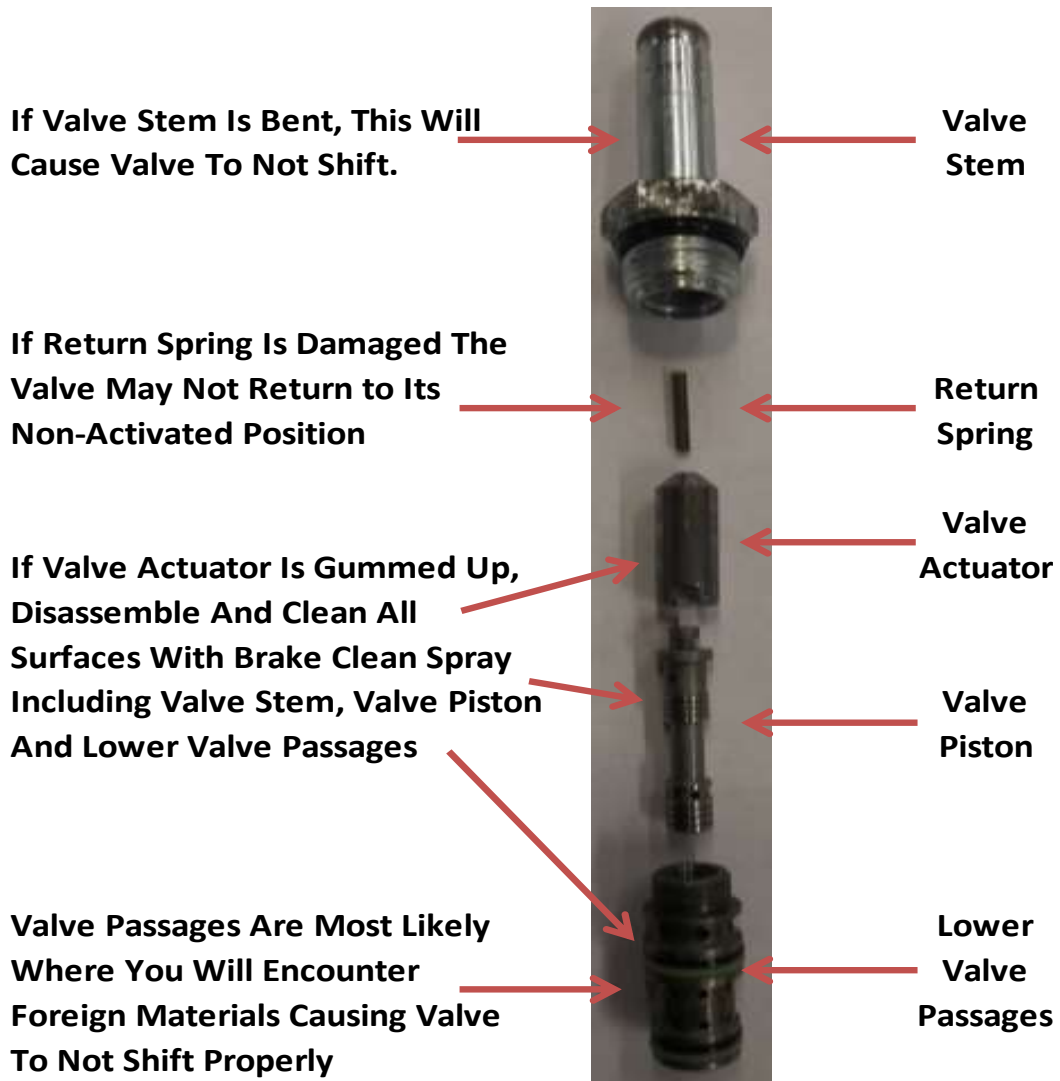

If The Lower Valve Passages Becomes Separated From The Valve Stem Upon Removal And Is Stuck In The Manifold, First Account For All The Parts Shown Here. A Tool Can Be Made For Removal By Simply Taking A Used Valve Stem And Grinding Off The Outer Threads Which Can Then Be Threaded Onto The Lower Passages Stuck In The Manifold For Easy Removal.



# Hydraulic Wing Gen 1 Power Unit Schematic – AA02-0007

Lift/Lower Circuit

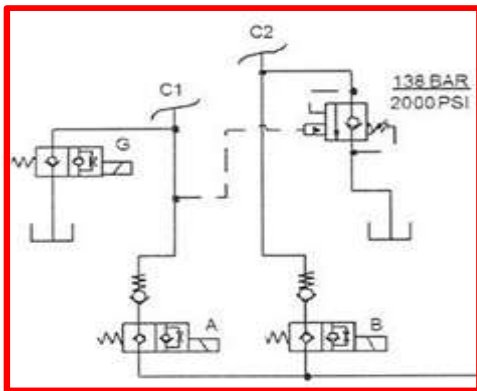

Right Wing Circuit

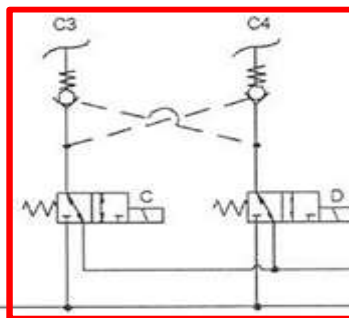

Left Wing Circuit

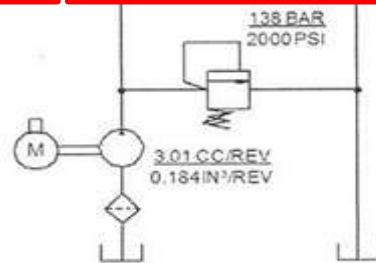
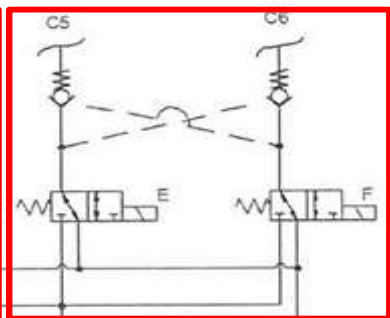



## Wing Check Valves Gen 1 Schematic – AA02-0007

### Right Wing Open Circuit Example

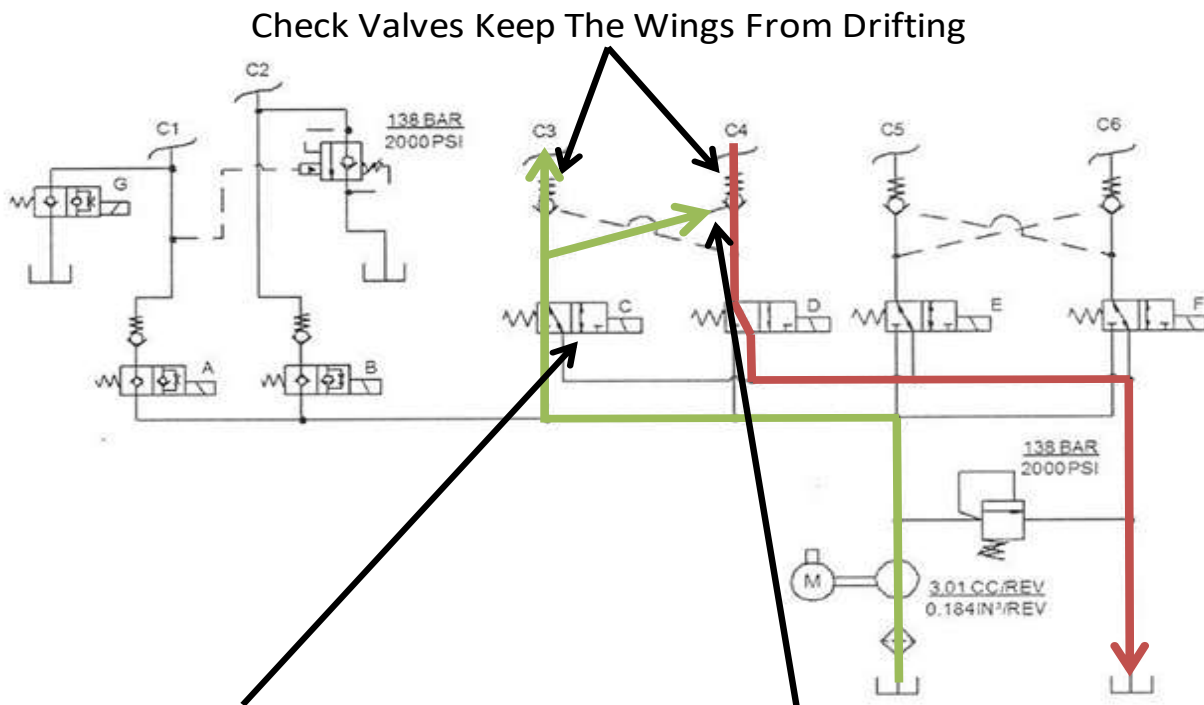

When "C" Valve Shifts It Also Shifts The Check Valve On The Opposite Side Of The Hydraulic Circuit Allowing The Fluid To Return To Tank.

If Check Valve Or Piston Is Damaged, Contaminated Or Missing The Circuit Cannot Be Completed And This Will Mimick A Bad "C" Valve Problem  
This Is Also True For Valves "D", "E" And "F"



## Hydraulic Wing Gen 1 Check Valve Locations - AA02-0007

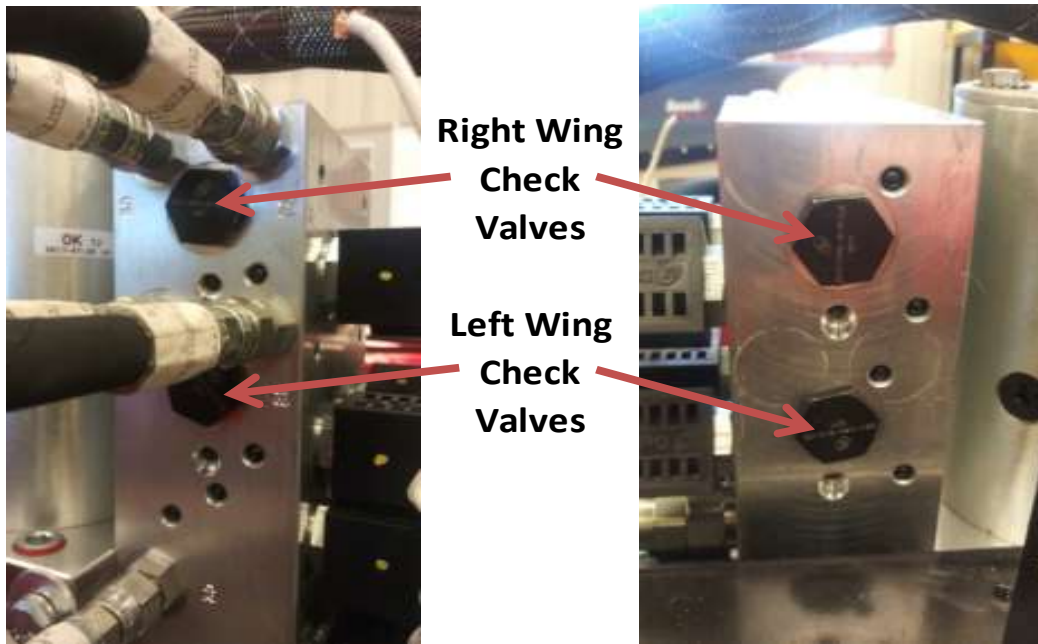

Check Valve Set #AA02-0039





## Hydraulic Wing Gen 1 Pump Valve Chart – AA02-0007

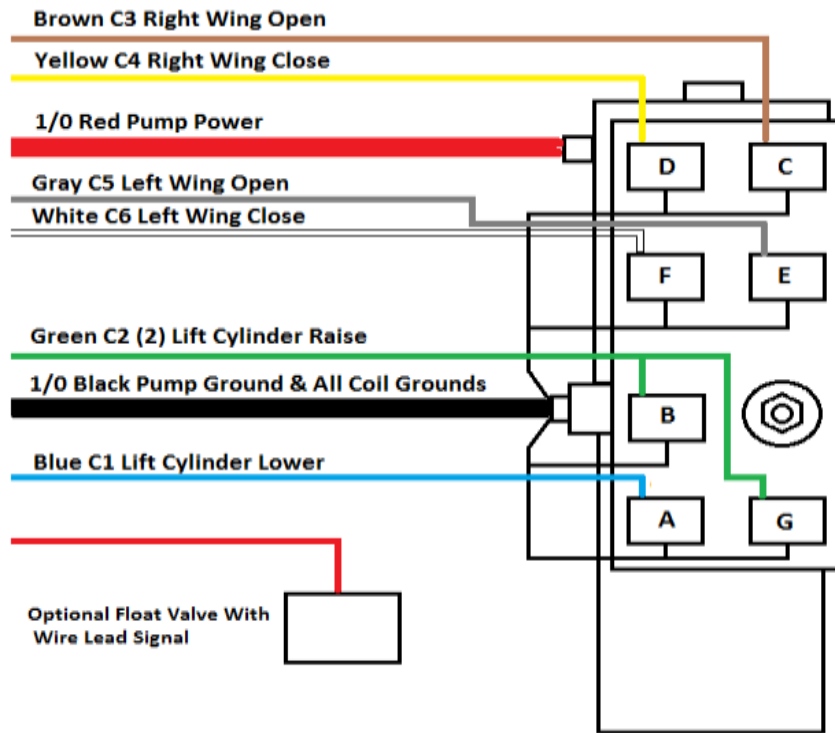

	R Wing		R Wing		L Wing		L Wing	Float
	Lower	Raise	Open	Close	Open	Close		
Motor	ON	ON	ON	ON	ON	ON		
A Valve	ON							
B Valve		ON						
C Valve			ON					
D Valve				ON				
E Valve					ON			
F Valve						ON		
G Valve		ON						ON
Float Valve								ON
Counterbalance	FLOW							



## Hydraulic Wing Gen 1 Open Circuit – AA02-0007

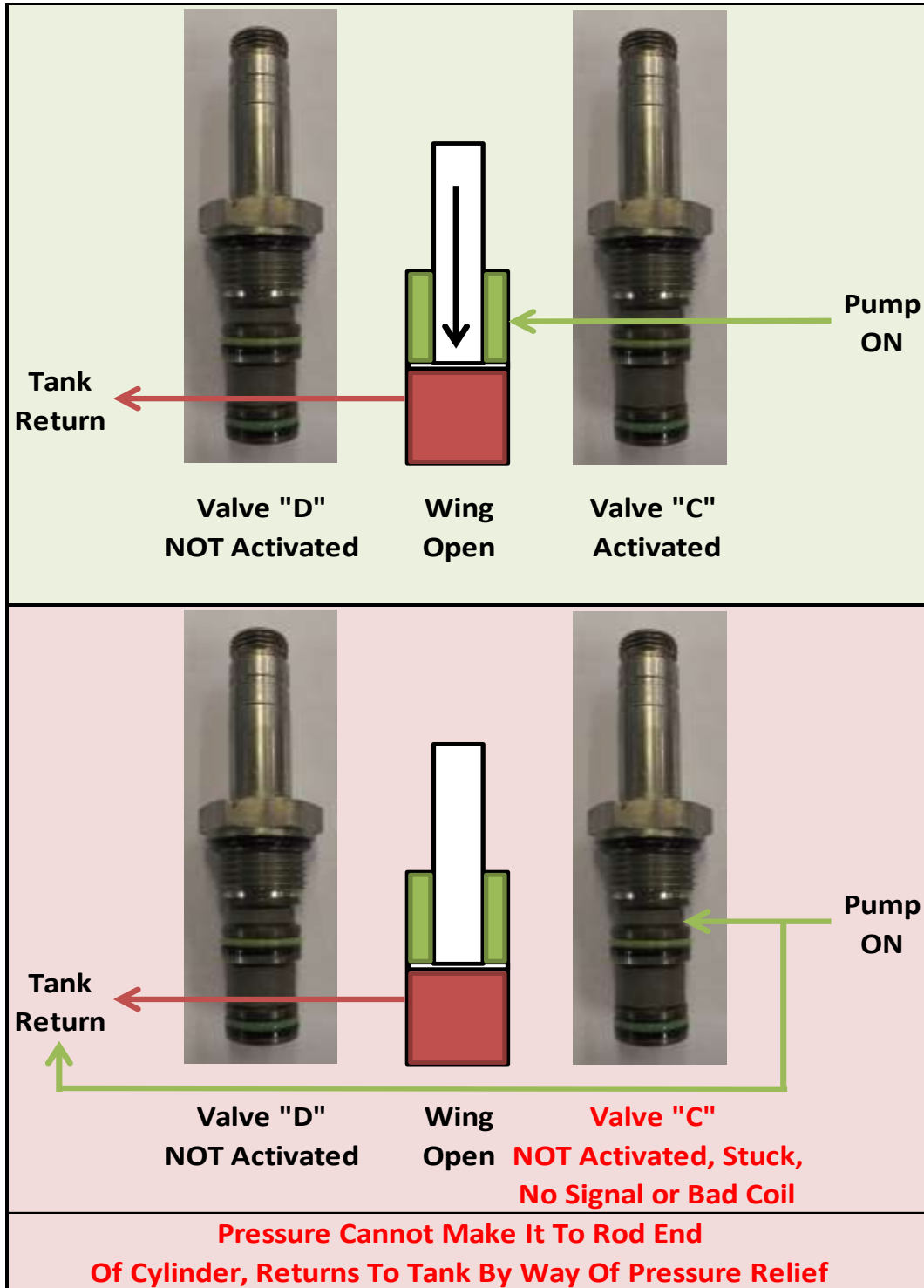



## Hydraulic Wing Gen 1 Close Circuit – AA02-0007

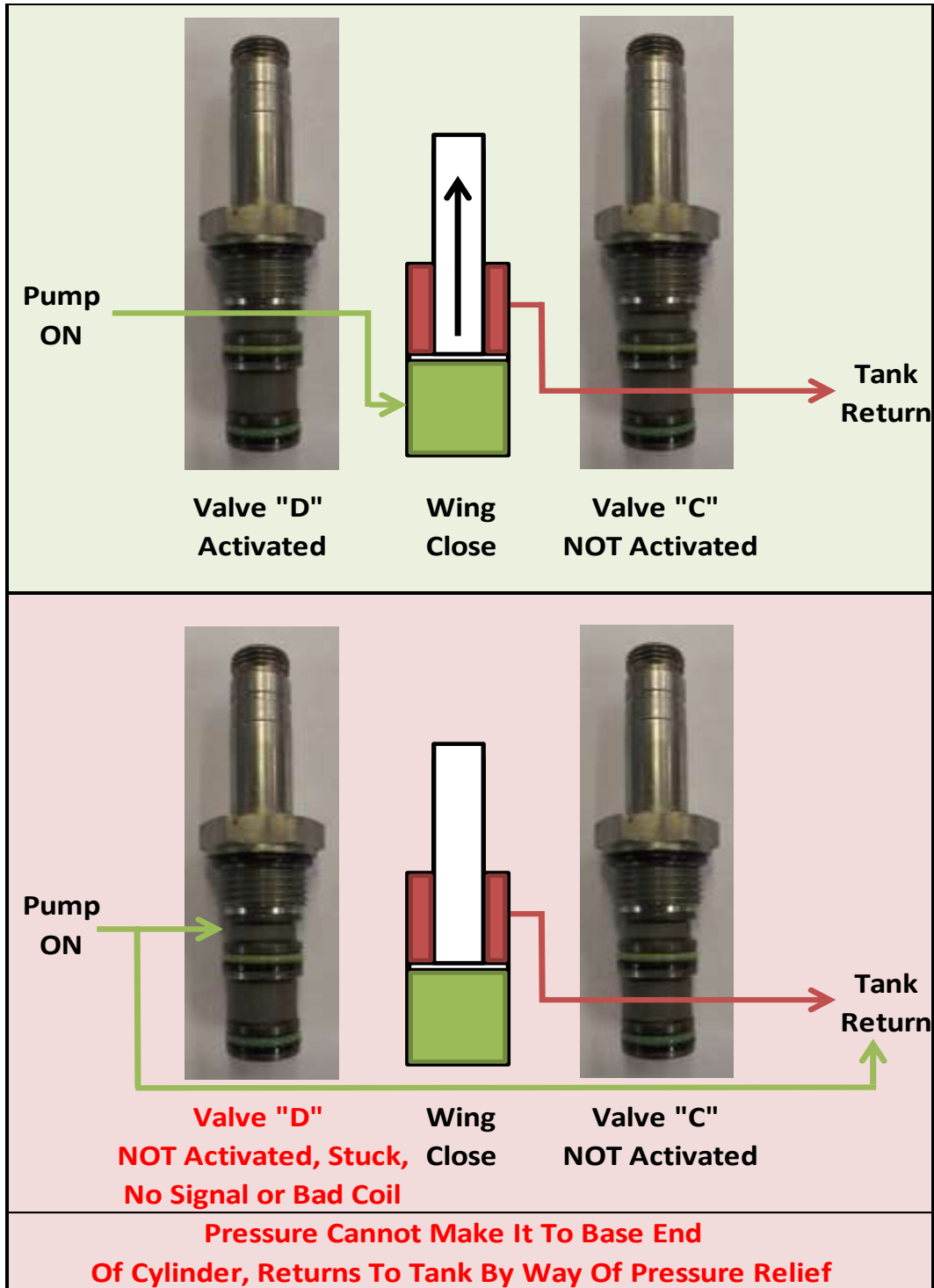



## Hydraulic Wing Gen 1 Lift Circuit – AA02-0007

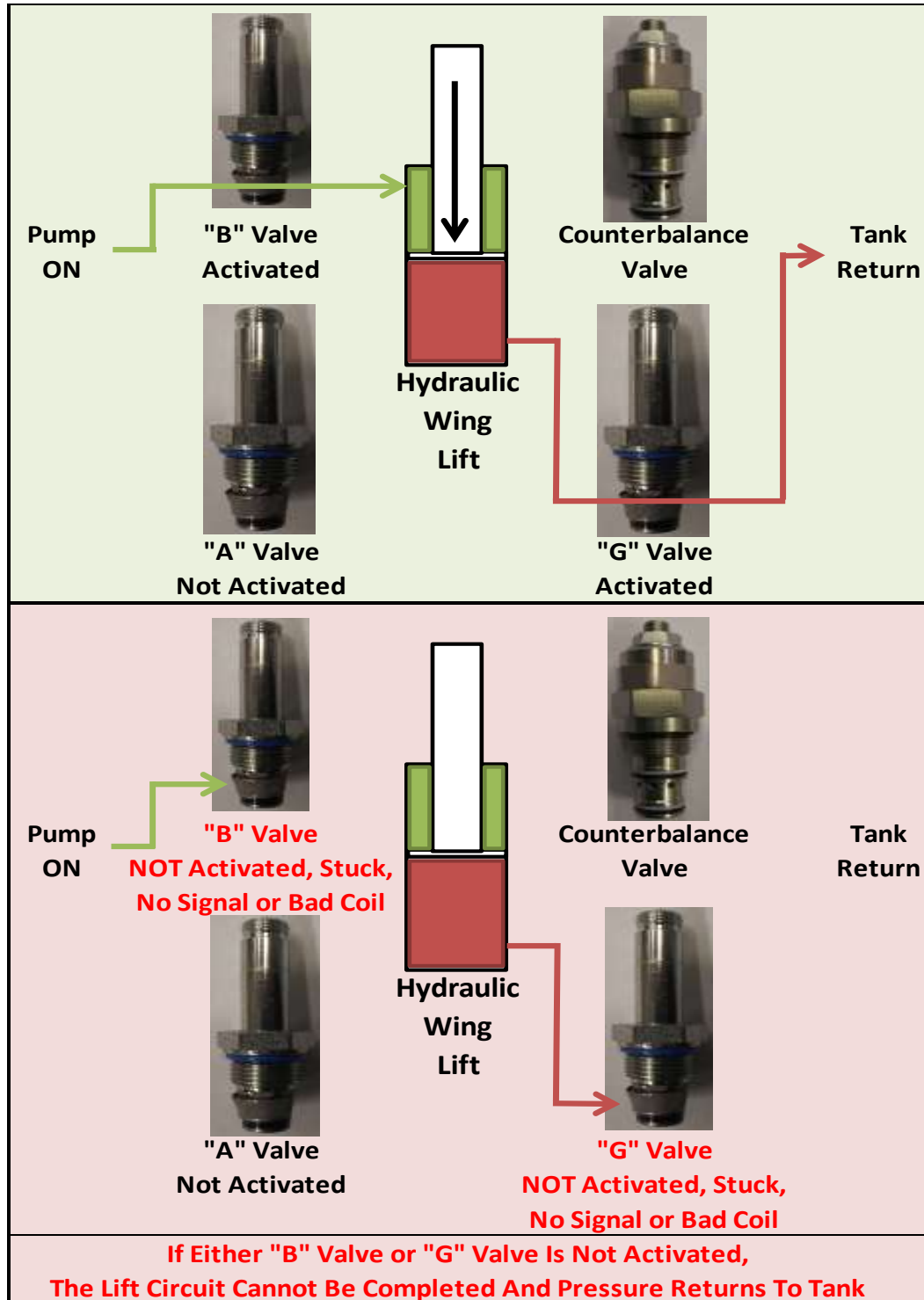



## Hydraulic Wing Gen 1 Lower Circuit – AA02-0007

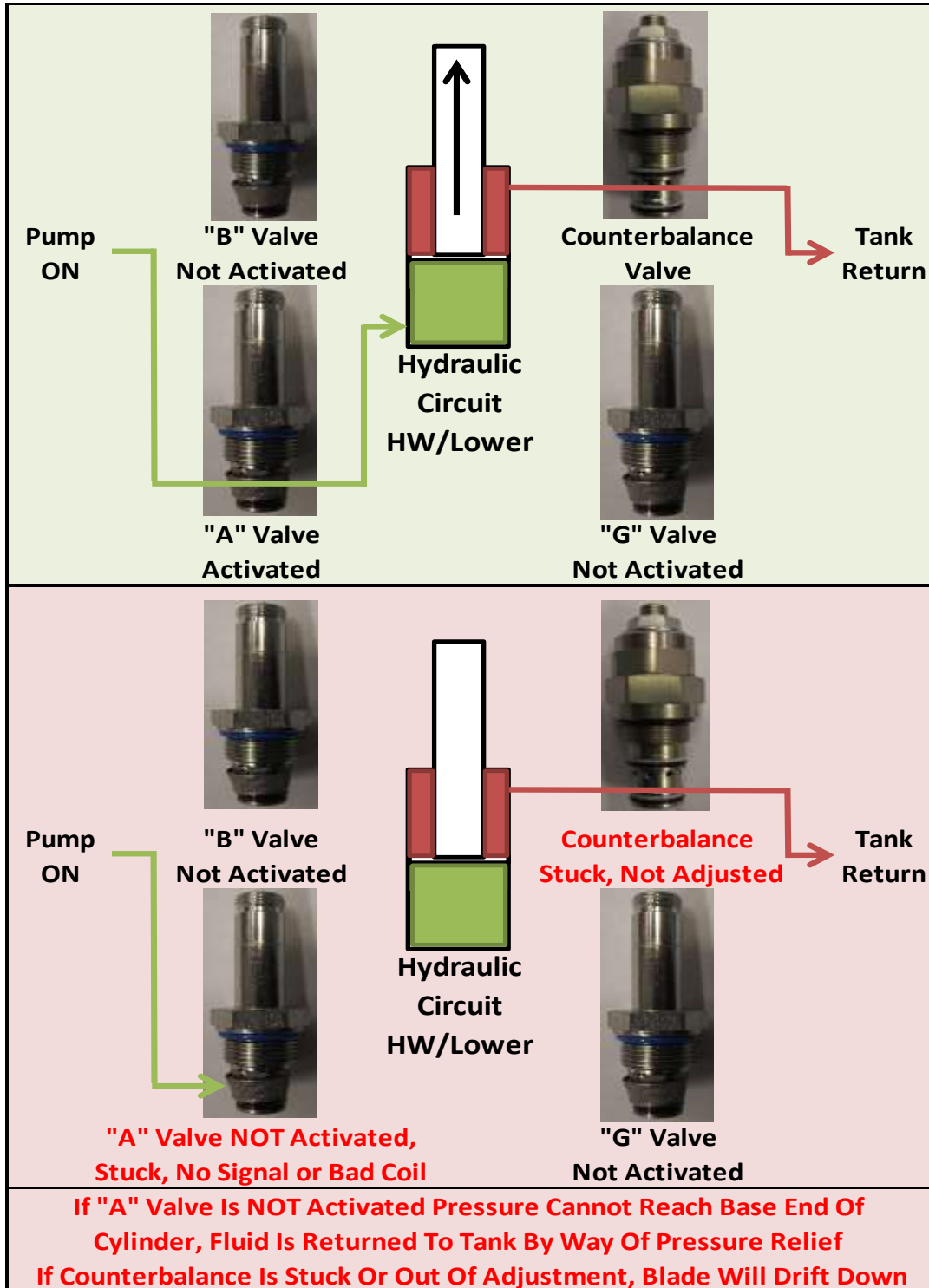



## Hydraulic Wing Gen 1 Float Circuit – AA02-0007

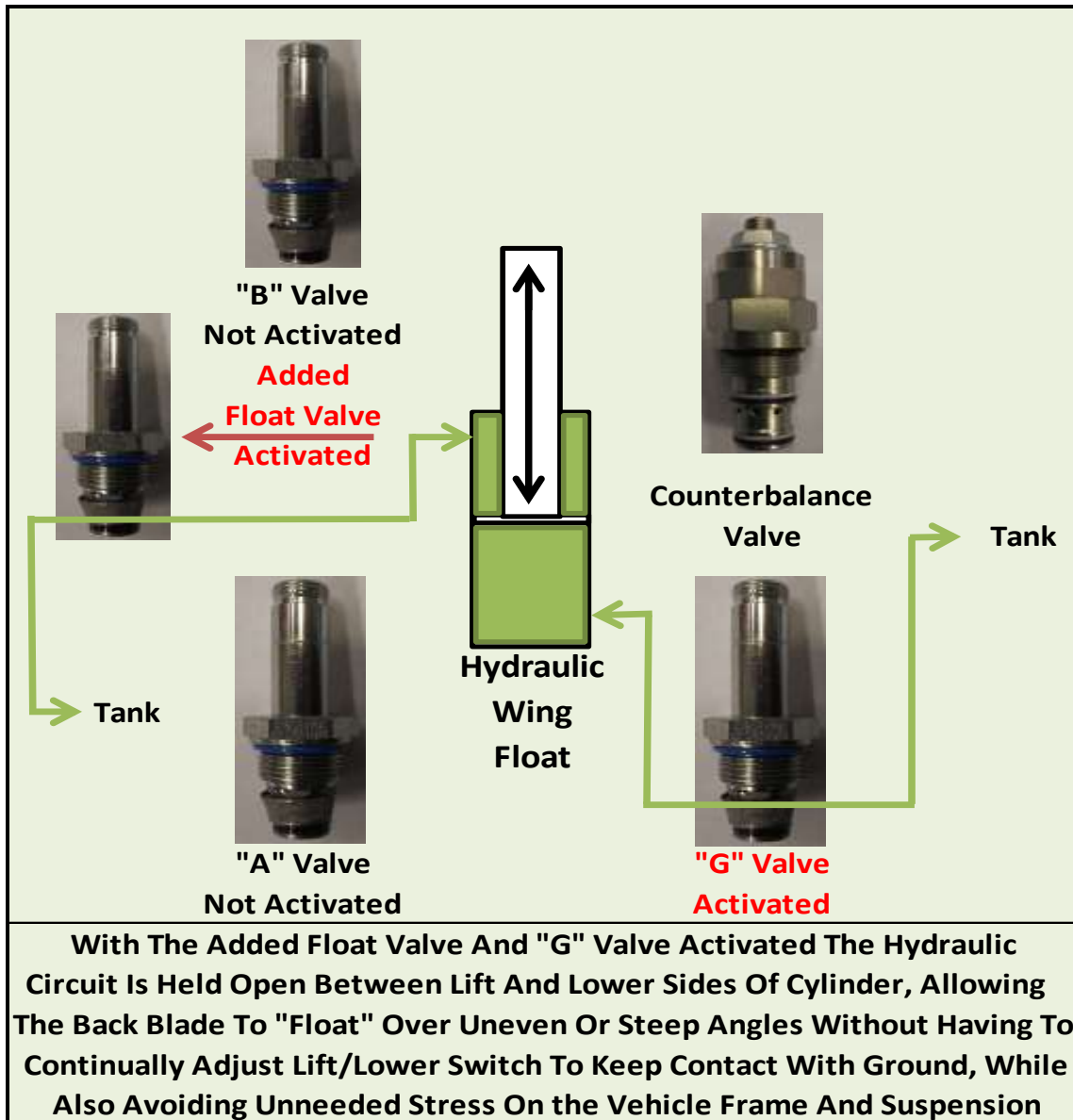





## Wing Check Valve Schematic Gen 2 – AA02-0007-F

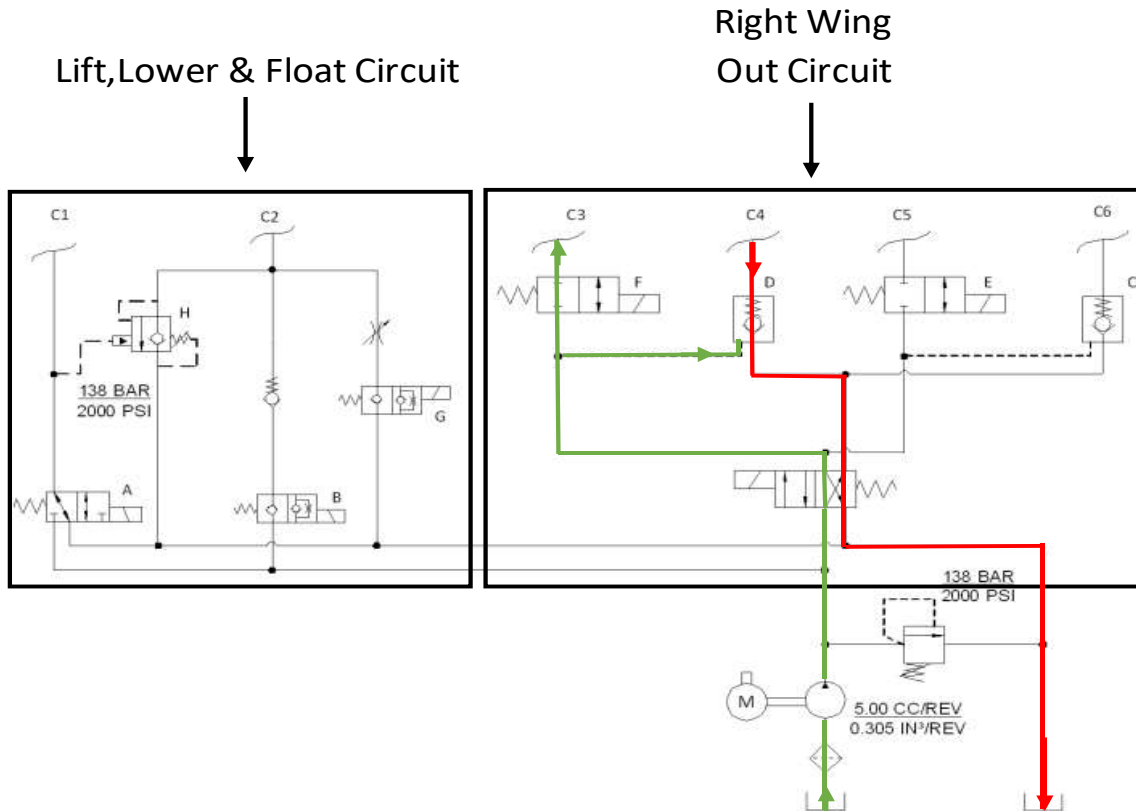

When "F" Valve Shifts It Also Shifts The Check Valve On The Opposite Side Of The Hydraulic Circuit Allowing The Fluid To Return To Tank. If Check Valve Or Piston Is Damaged, Contaminated Or Missing The Circuit Cannot Be Completed And This Will Mimick A Bad "F" Valve Problem  
This Is Also True For Valve "E"



## Hydraulic Wing Pump Valve Chart Gen 2 – AA02-0007-F

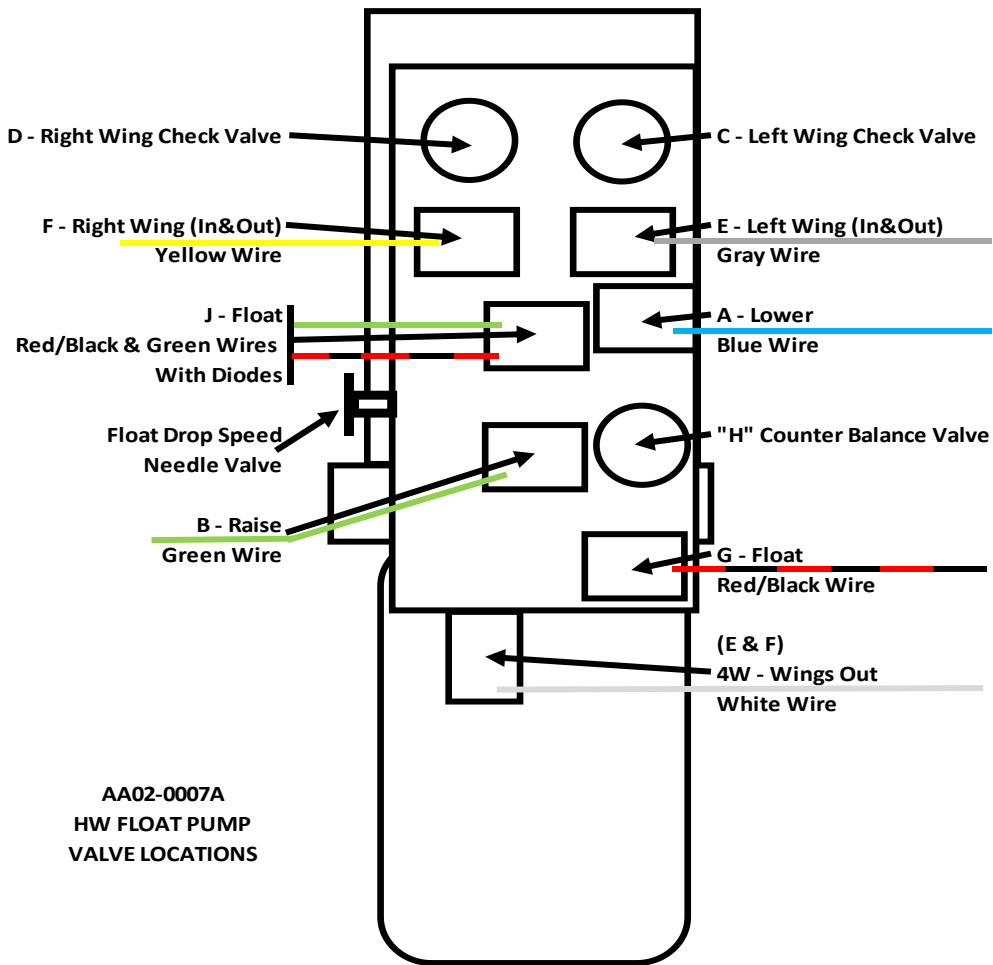

	Lower	Raise	R Wing Open	R Wing Close	L Wing Open	L Wing Close	Float
Motor	ON	ON	ON	ON	ON	ON	
A Valve	ON						
B Valve		ON					
E Valve					ON	ON	
F Valve			ON	ON			
G Valve							ON
J Valve		ON					ON
4W Valve			ON		ON		
Counterbalance	FLOW						



## Hydraulic Wing Open Circuit Gen 2 – AA02-0007-F

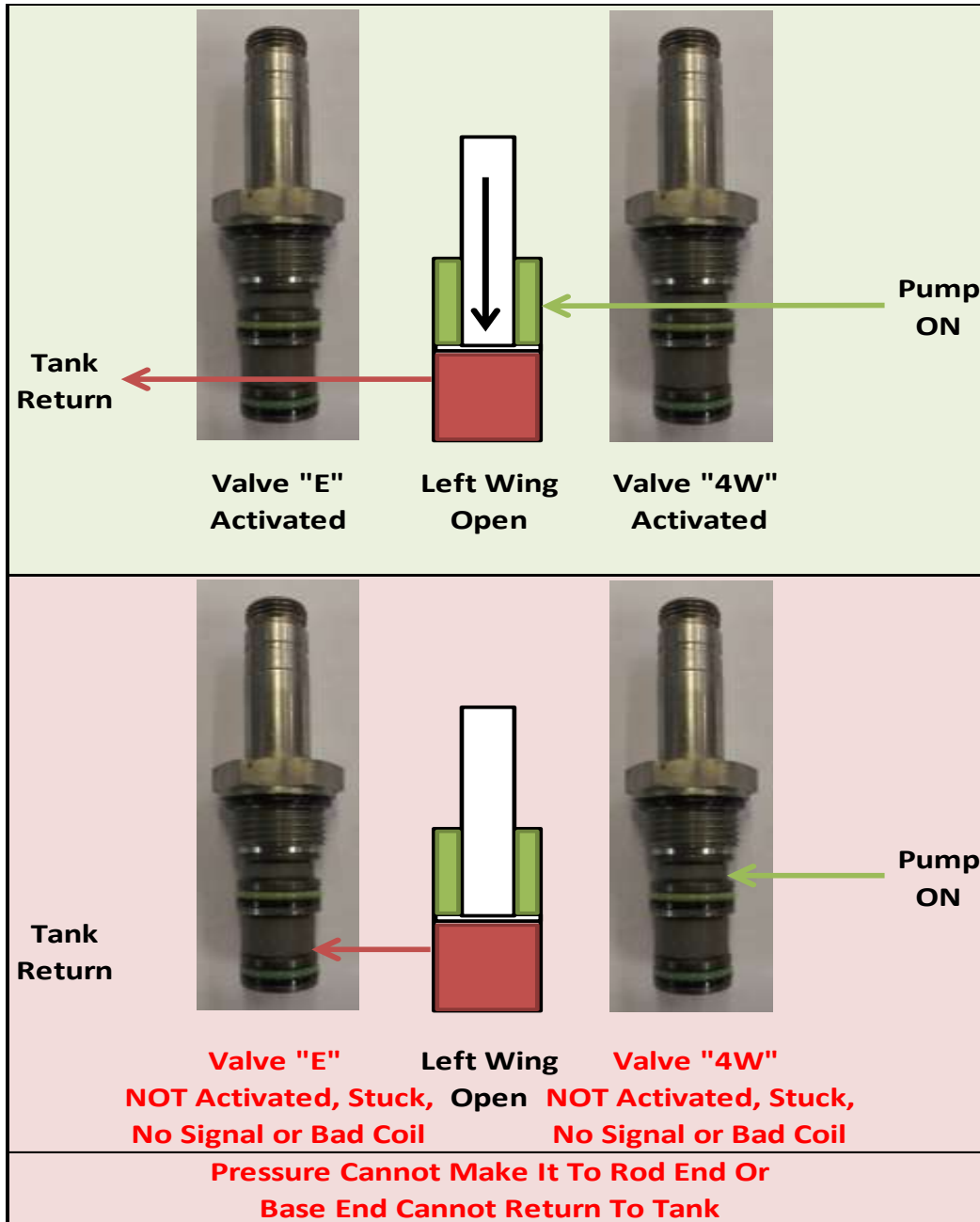



## Hydraulic Wing Close Circuit Gen 2 – AA02-0007-F

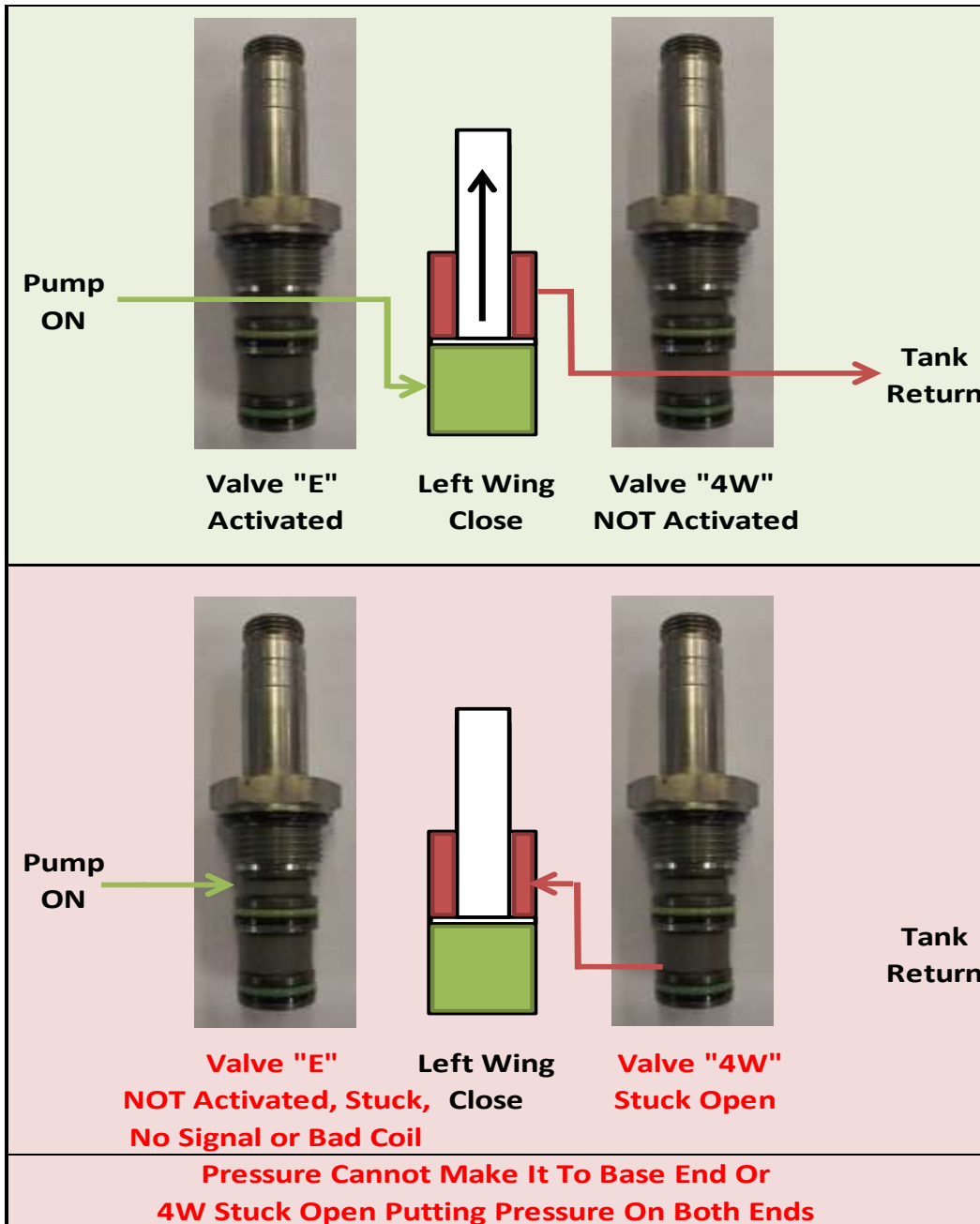



## Hydraulic Wing Raise Gen 2 – AA02-0007-F

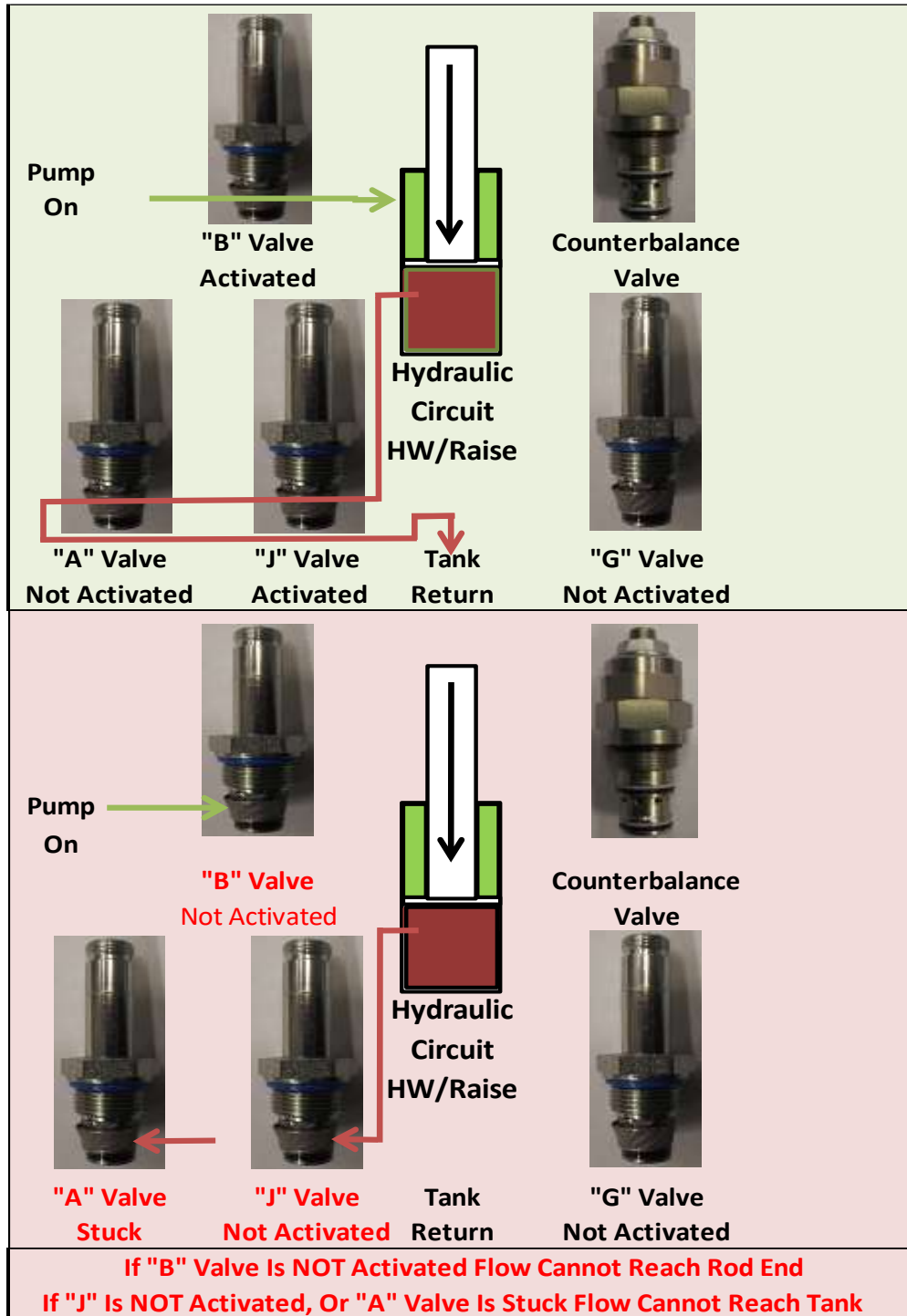



## Hydraulic Wing Lower Gen 2 – AA02-0007-F

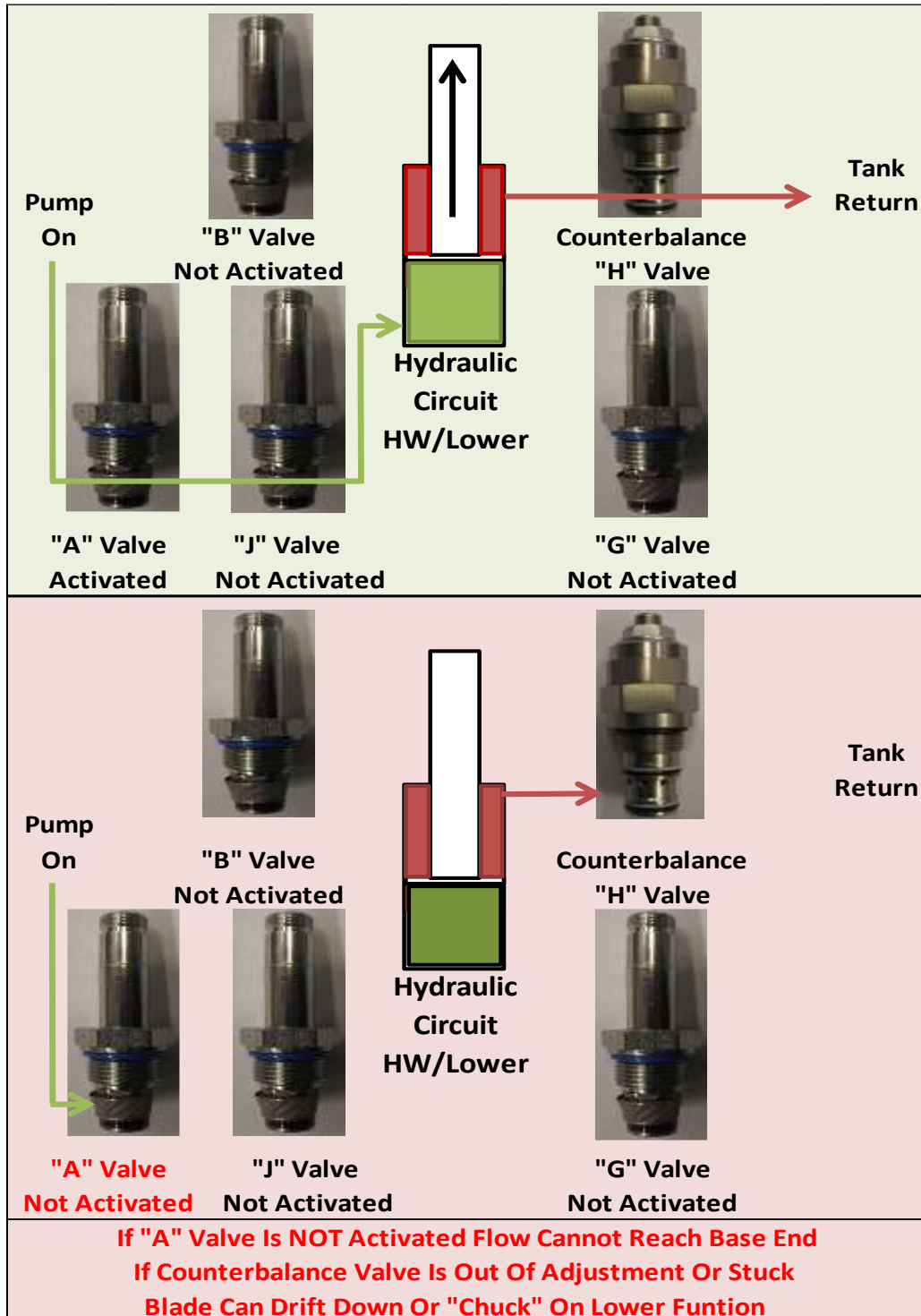



## Hydraulic Wing Float Circuit Gen 2 – AA02-0007-F

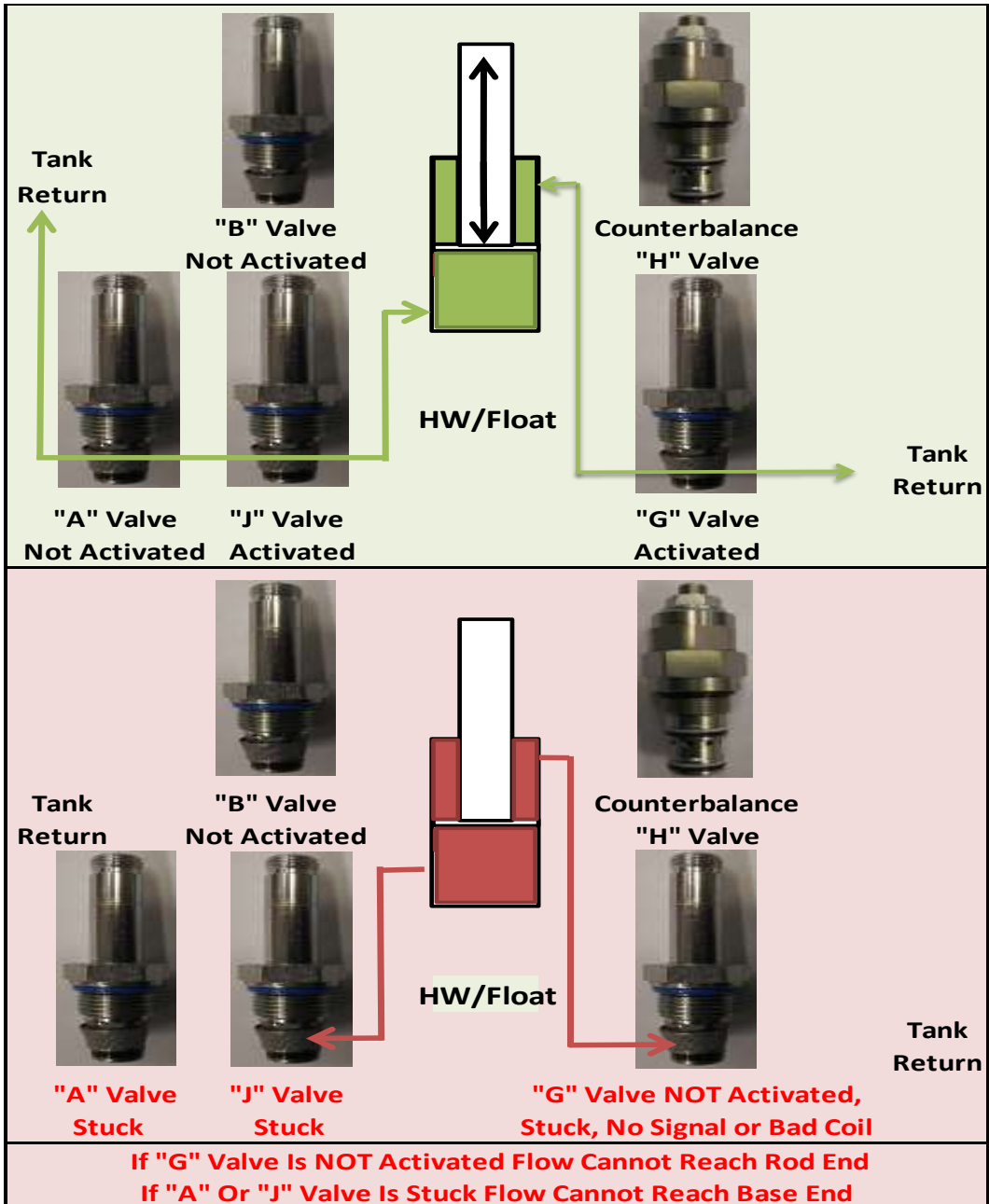



## Fixed Wing Hydraulic Schematic

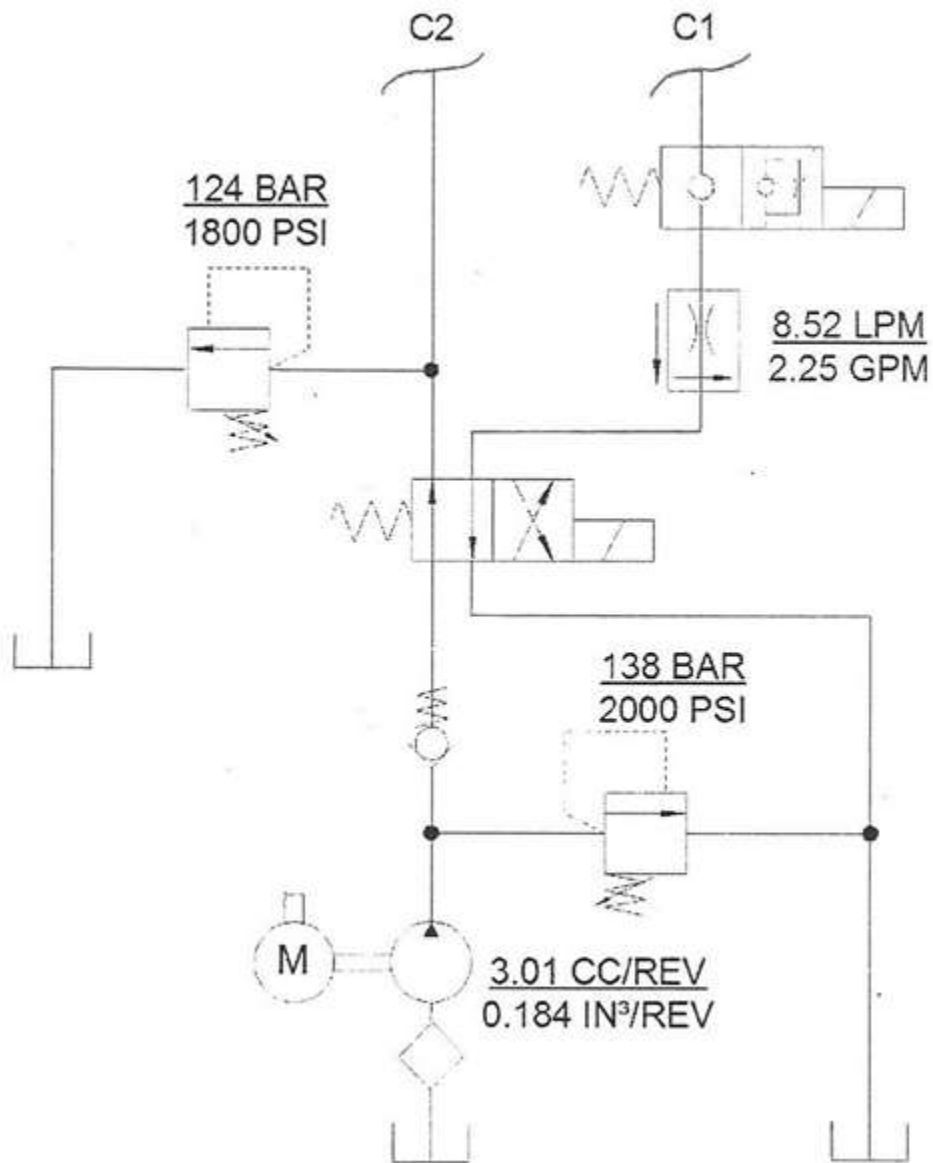



## Fixed Wing & sidekick Lift Circuit -

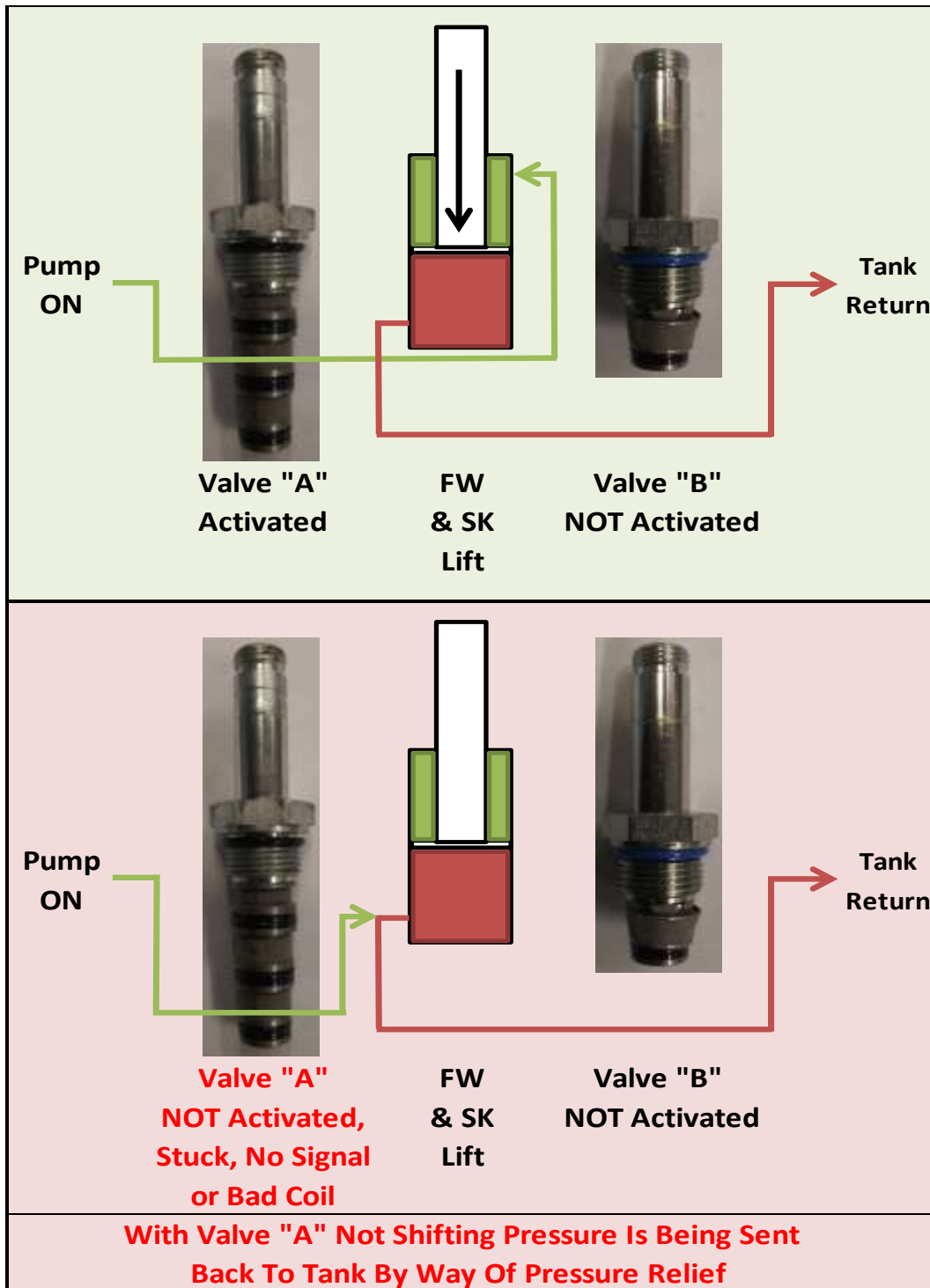



## Fixed Wing & sidekick Lower Circuit

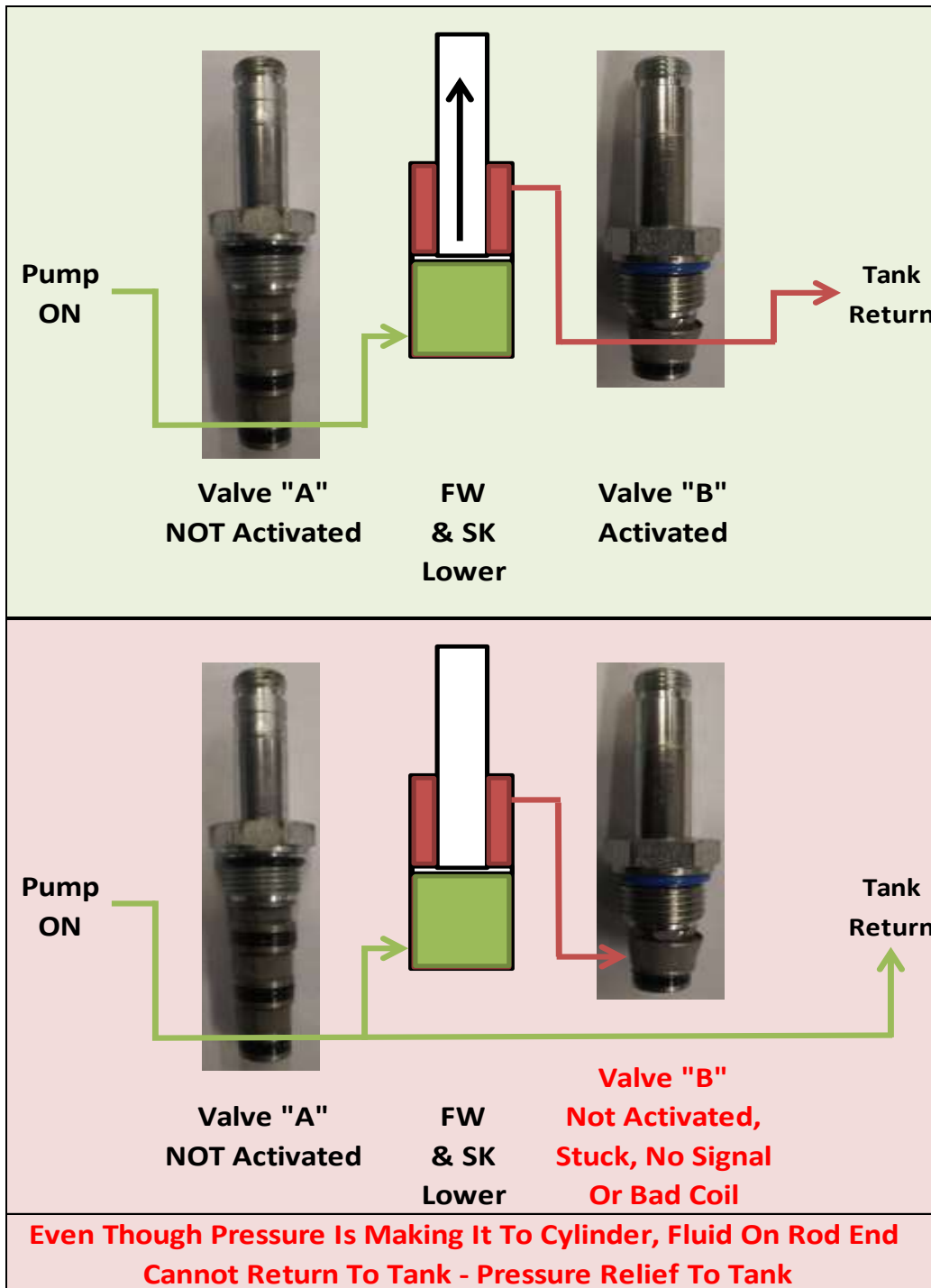



## Fixed Wing & sidekick Float Circuit

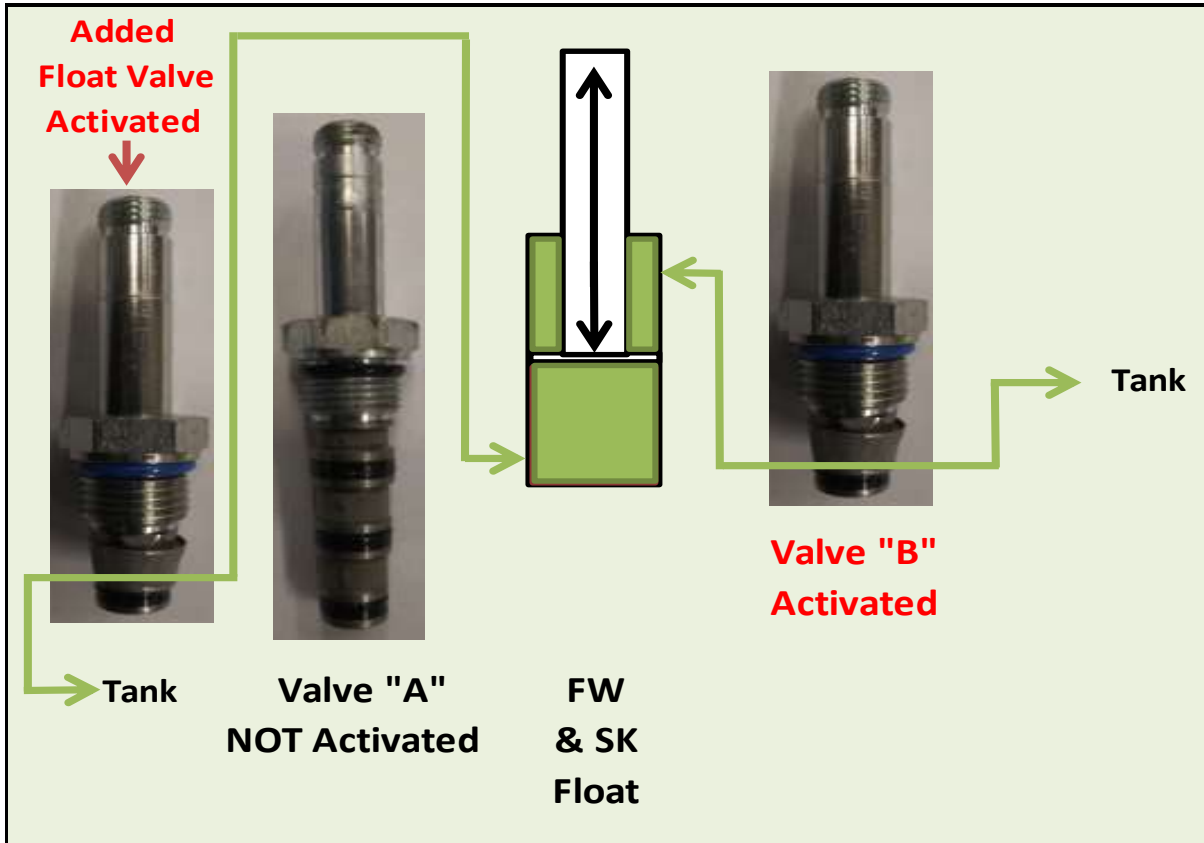

With The Added Float Valve And "B" Valve Activated The Hydraulic Circuit Is Held Open Between Lift And Lower Sides Of Cylinder, Allowing The Back Blade To "Float" Over Uneven Or Steep Angles Without Having To Continually Adjust Lift/Lower Switch To Keep Contact With Ground, While Also Avoiding Unneeded Stress On the Vehicle Frame And Suspension



## Truck Side Power Connections – Hydraulic & Fixed Wings

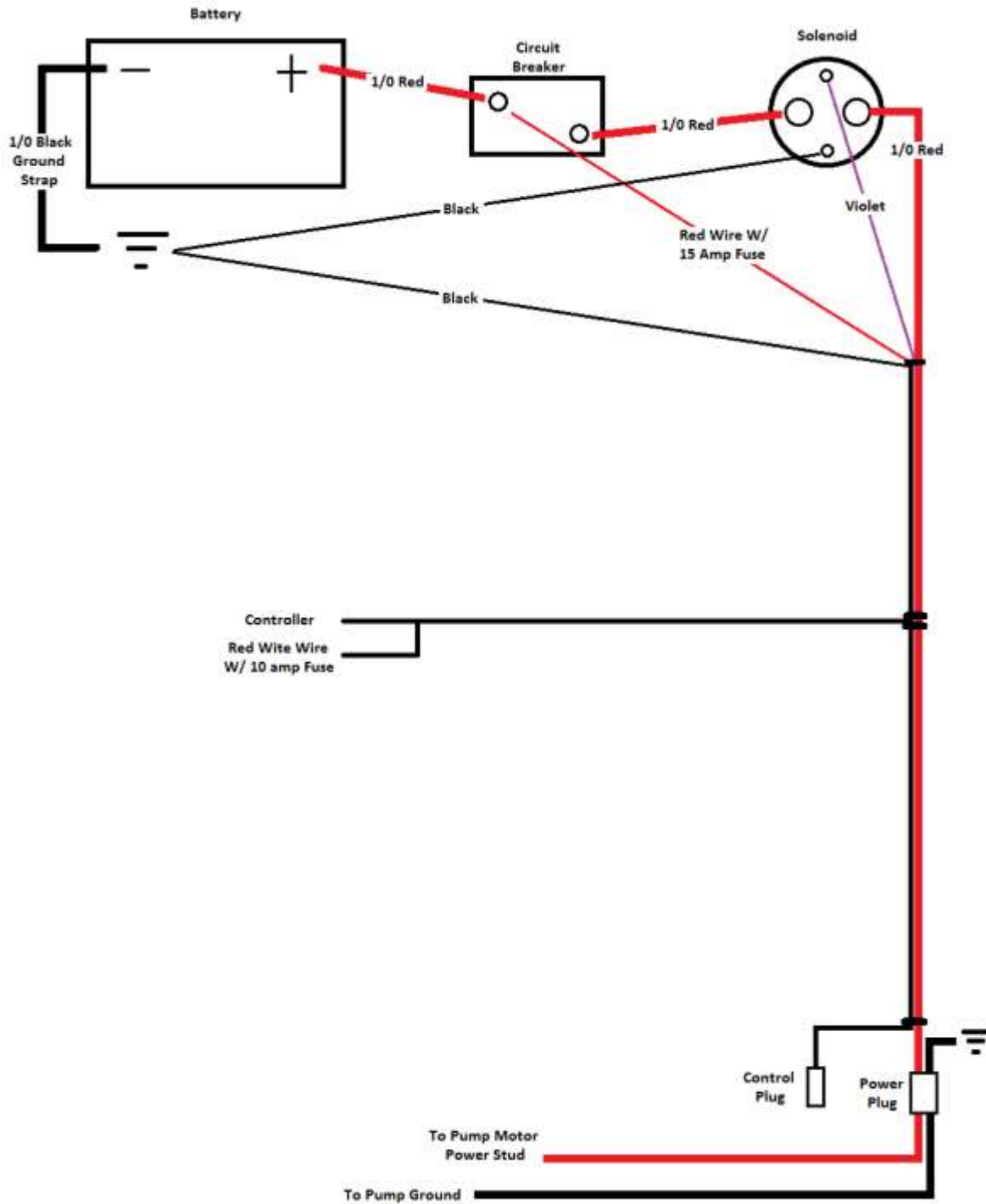



## Truck & Plow Side Control Plug Connections

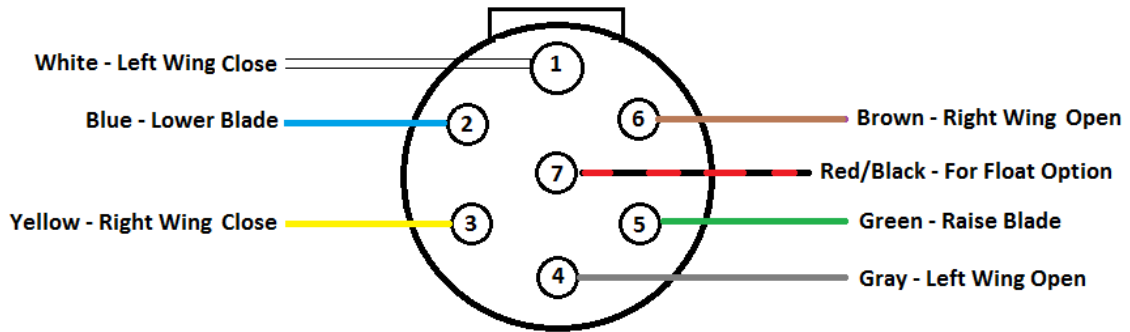

View Is REAR Of Truckside  
7-Way Control Plug

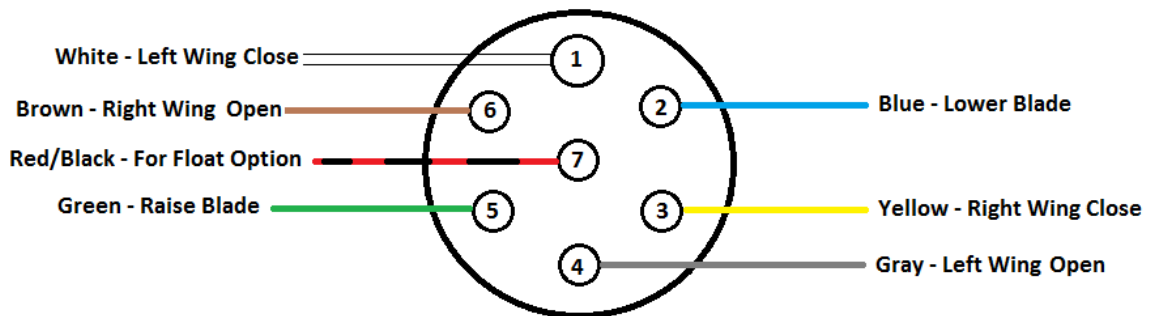

View Is REAR Of Plow Side  
7-Way Control Plug



## HW Gen 1 Pump Hydraulic & Electrical Connections – AA02-0007

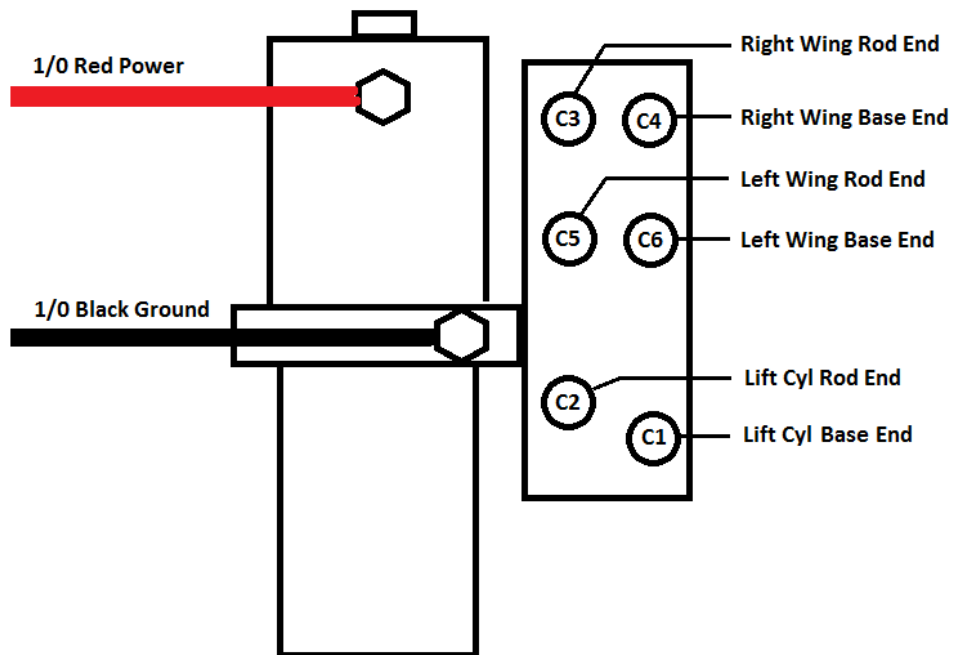
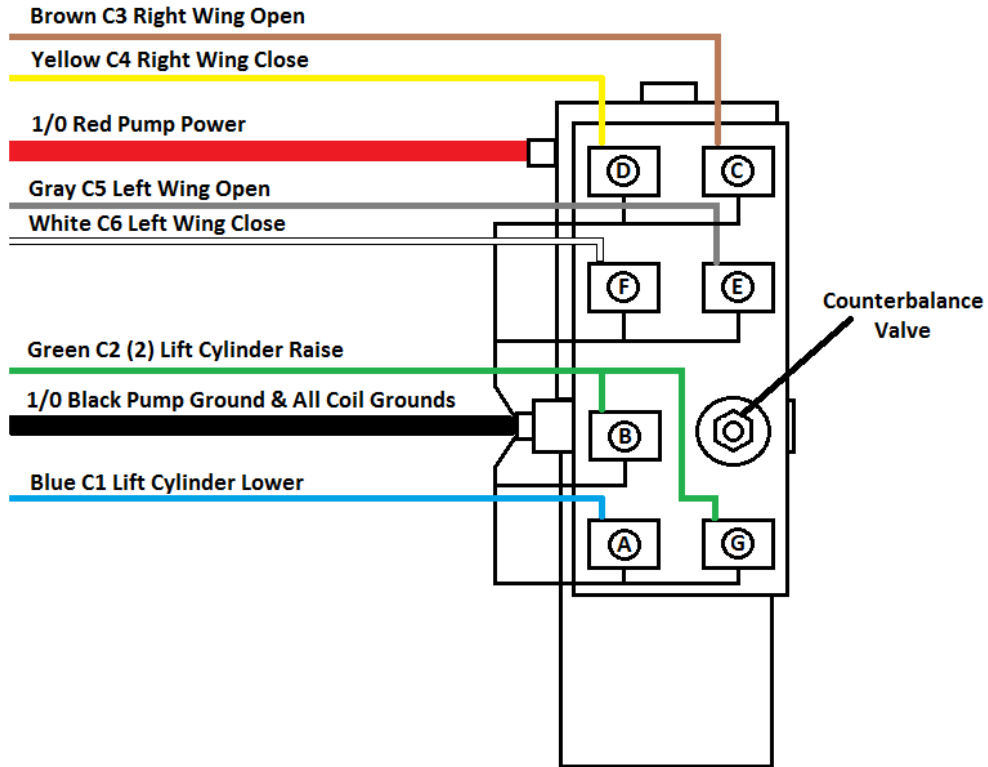



### HW Gen 2 Pump Hydraulic & Electrical Connections – AA02-0007-F

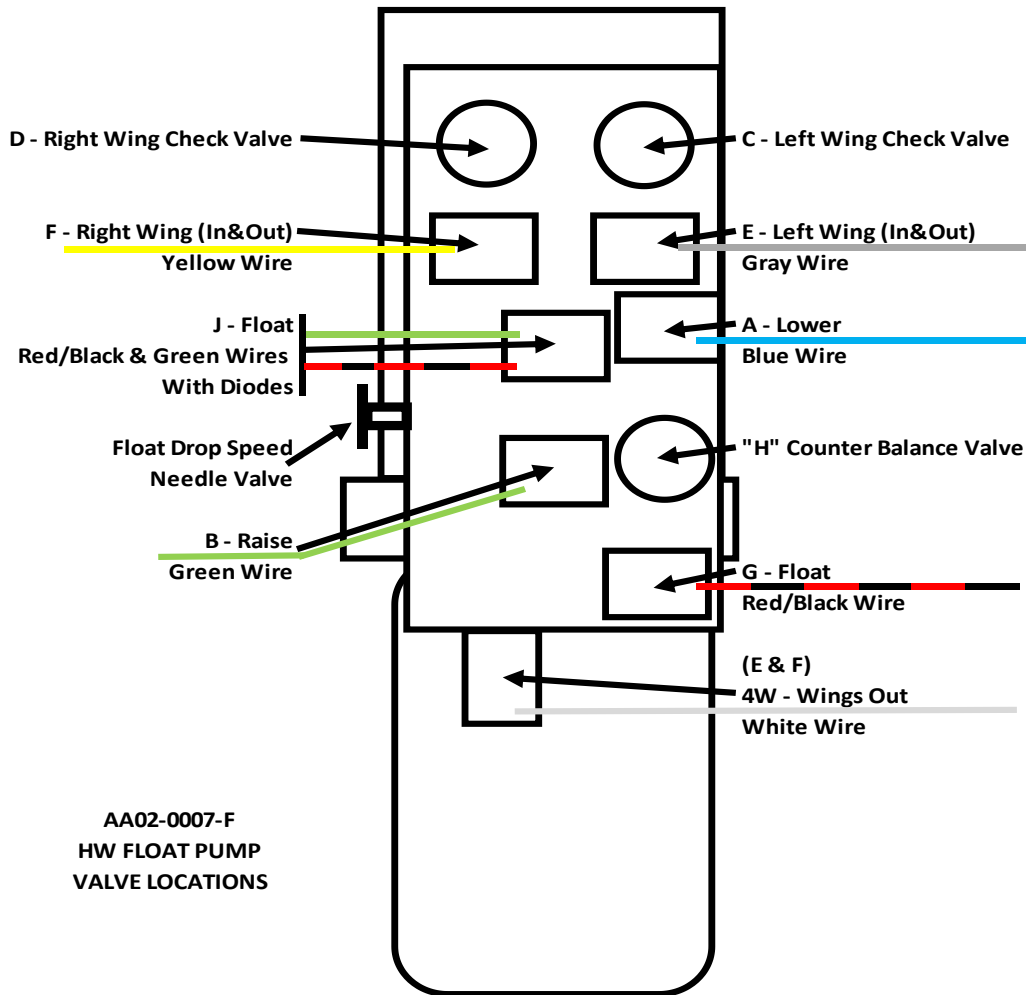



### HW Gen 2 Pump Hydraulic & Electrical Connections – AA02-0007-F

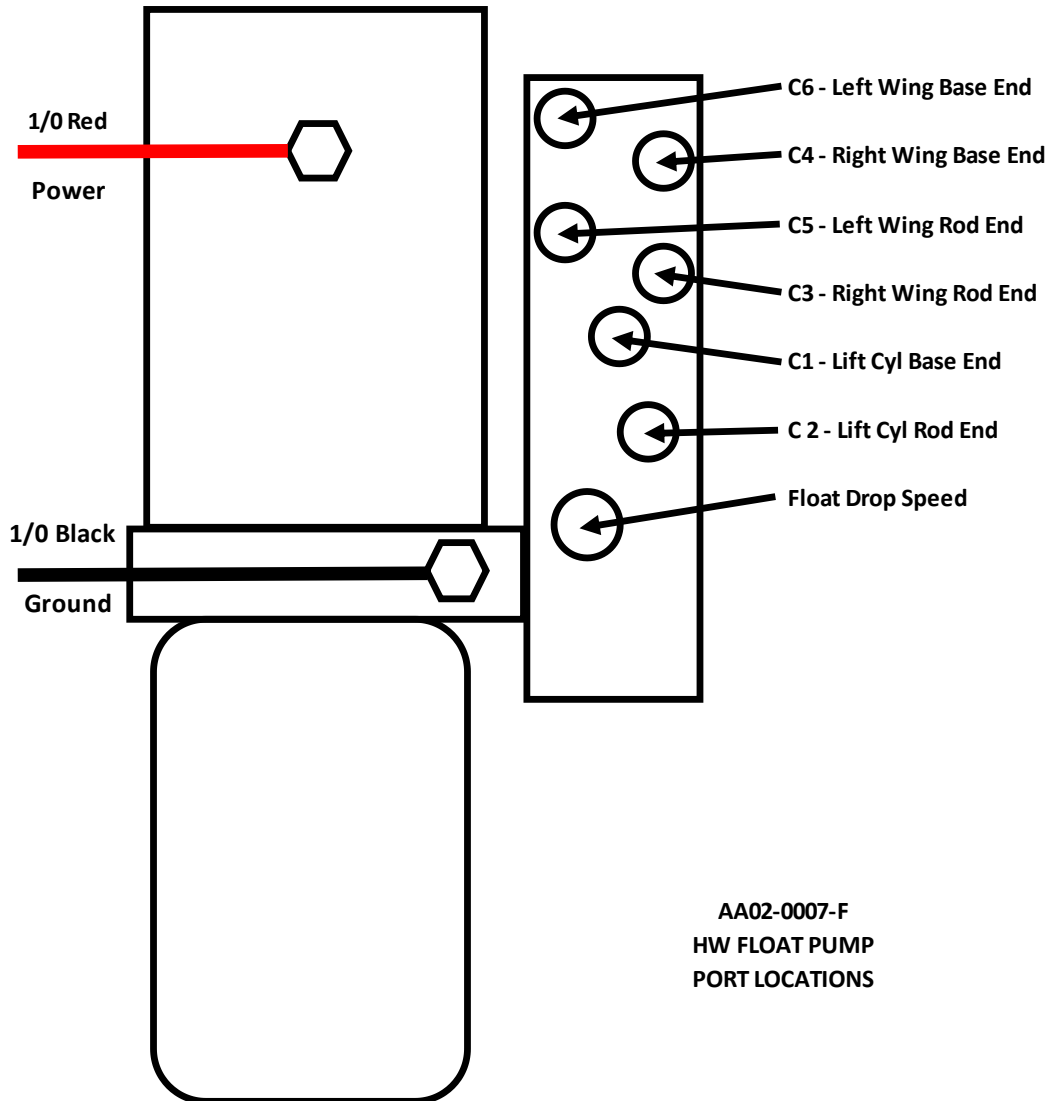



## Pump Hydraulic & Electrical Connections – Fixed Wings

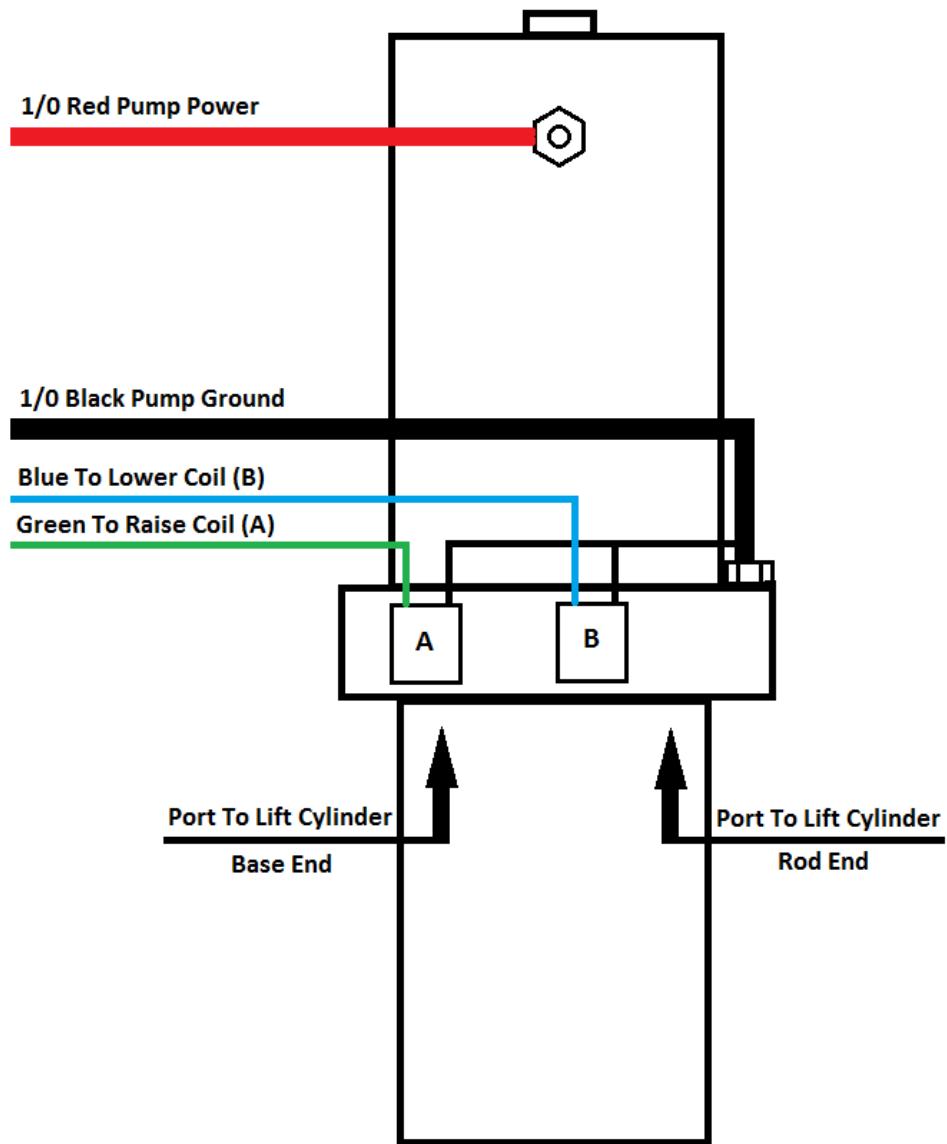



## Truck Side Control Harness Gen 1

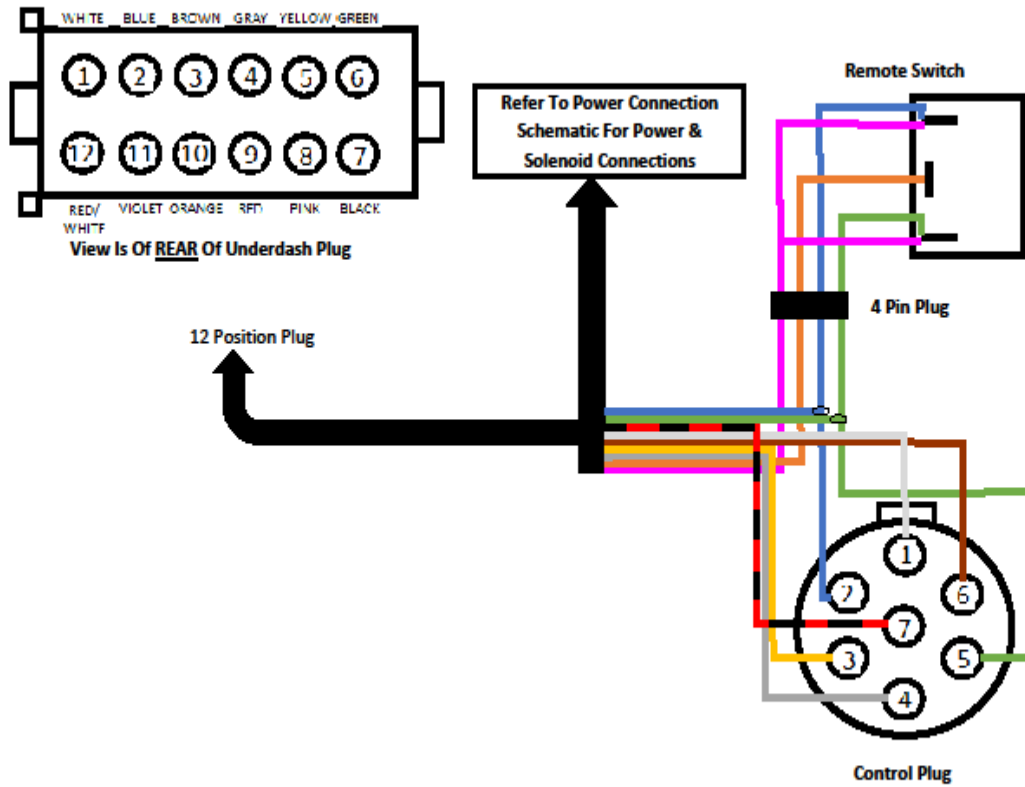



## Truck Side Control Harness Gen 2

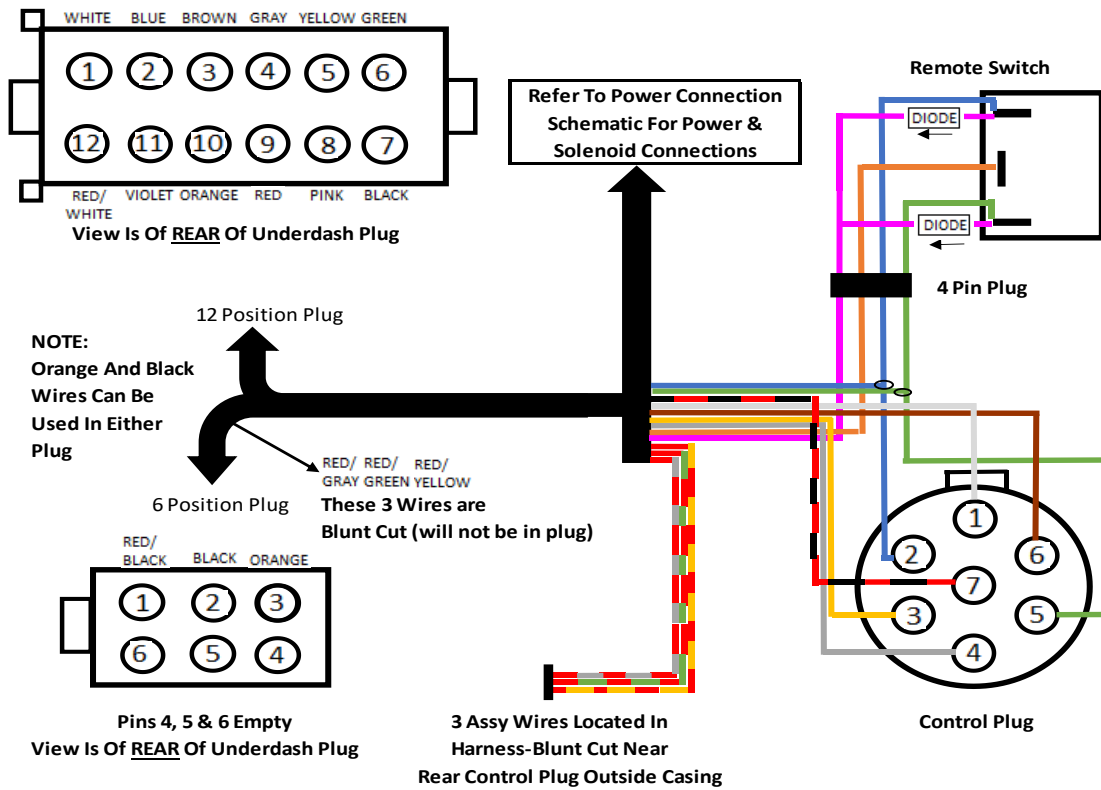



### Pump Side Wiring Harness – Gen 1 HW – AA02-0007

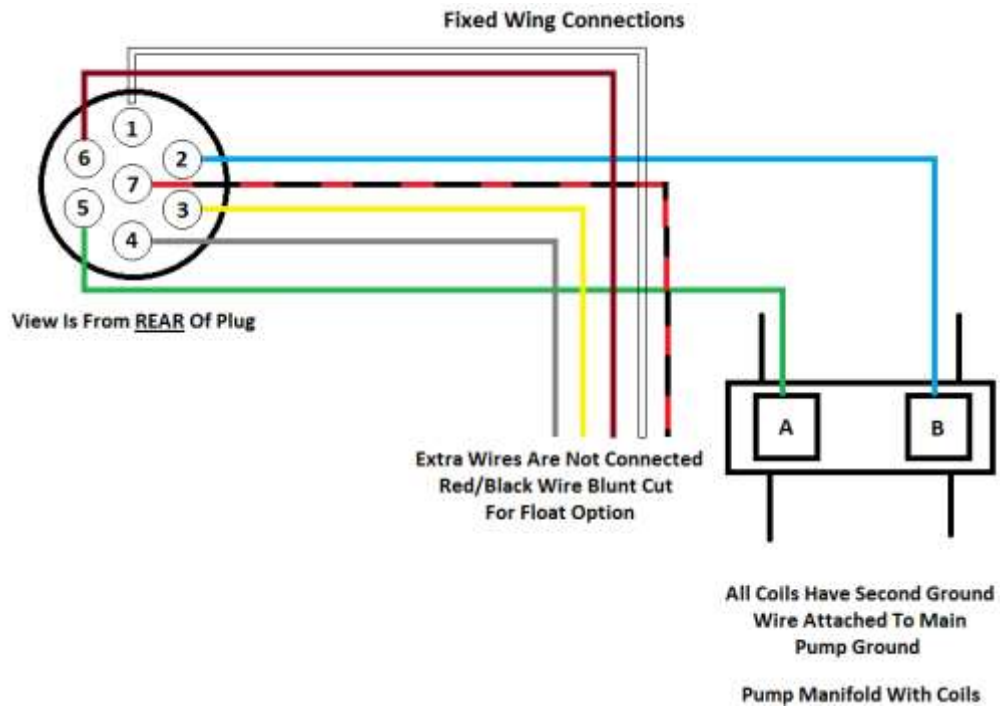
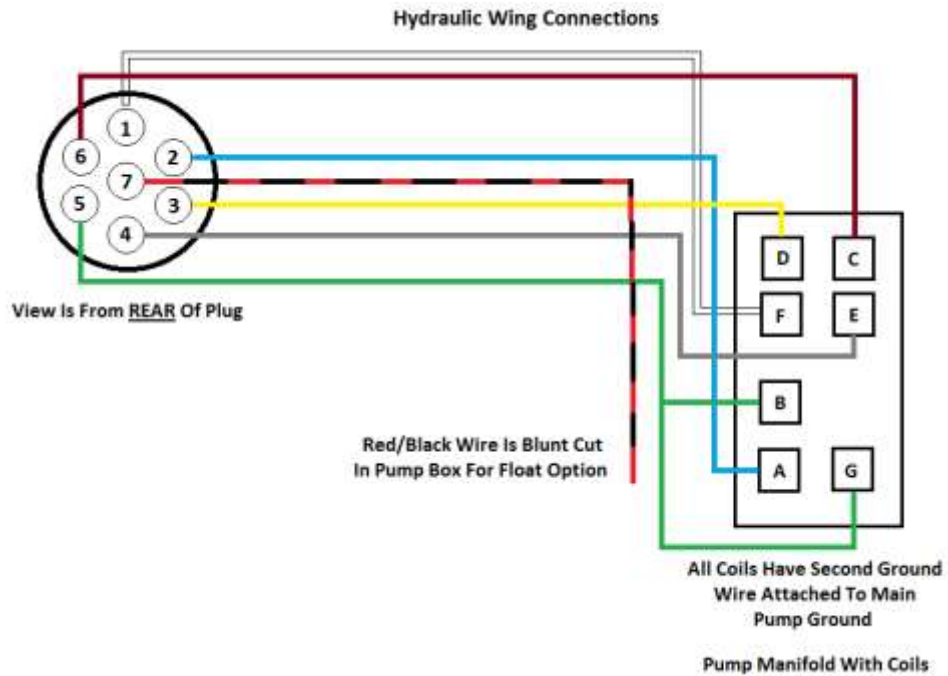



### HW Gen 2 Pump Side Wiring Harness– AA02-0007-F

View Is From REAR Of Plug

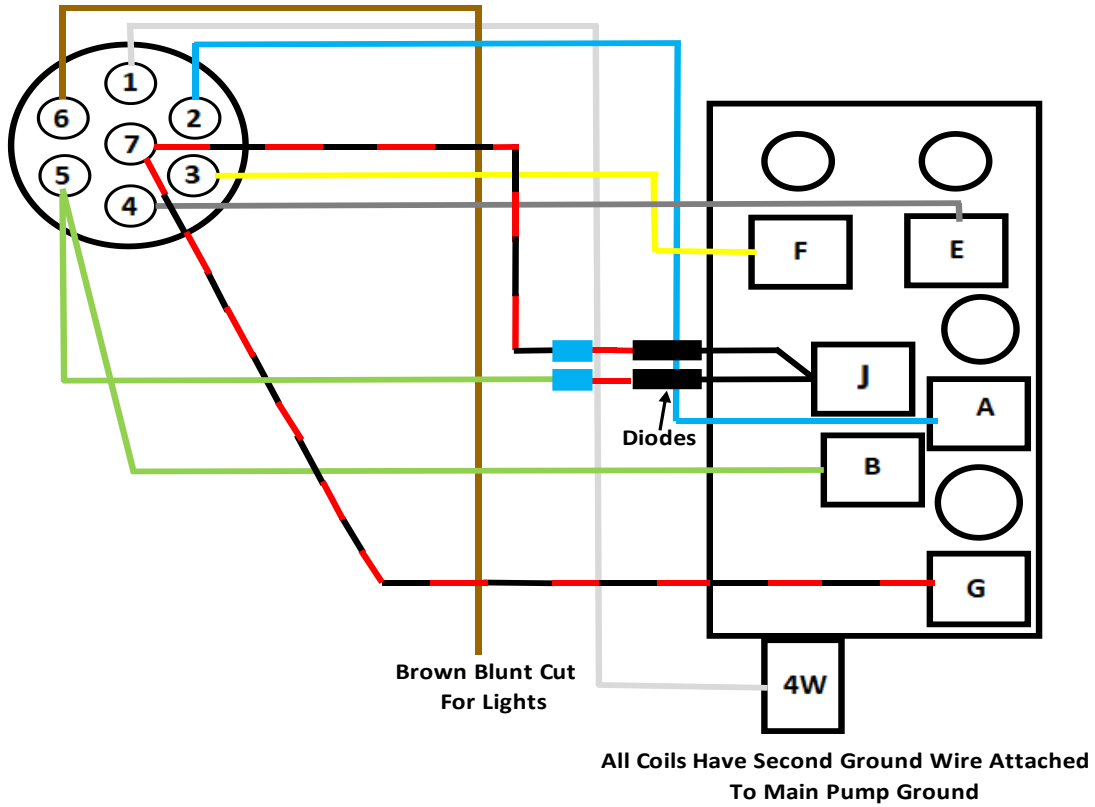



## Controller Switch Wiring – Gen 1 HW – 2 Pole Toggle Switches

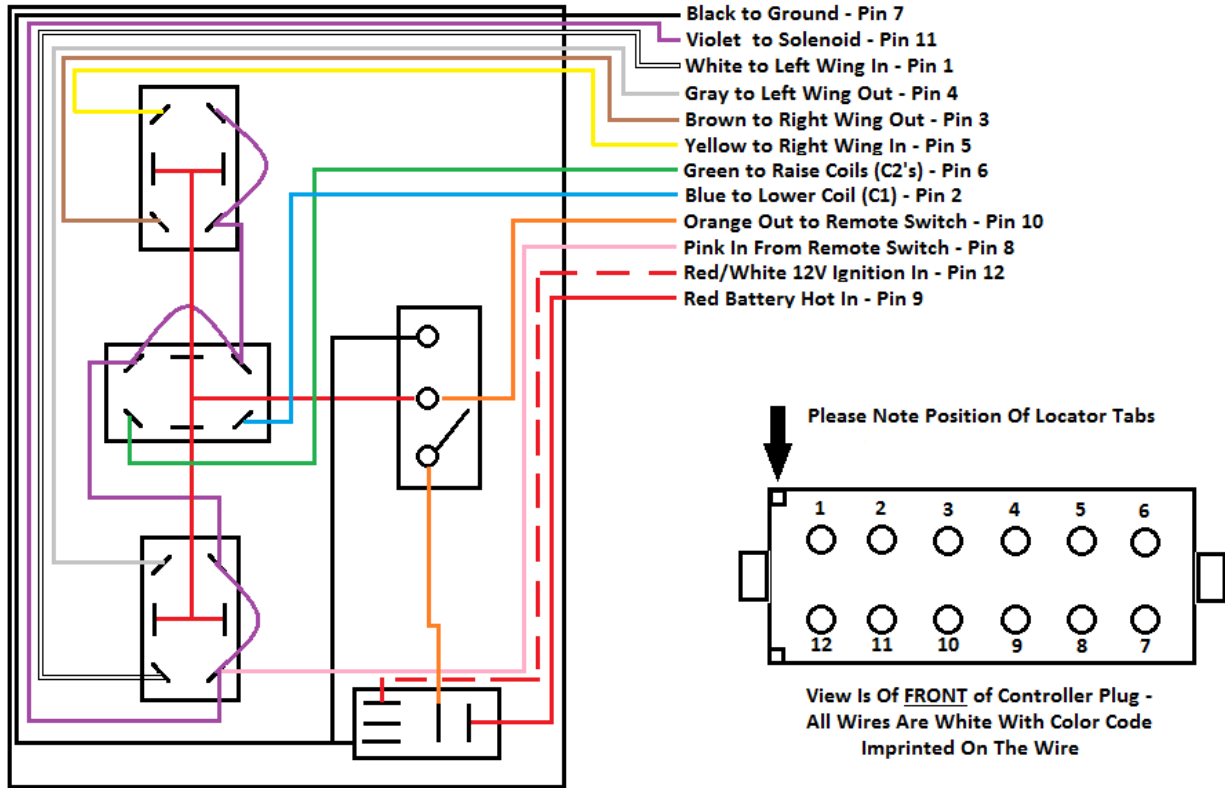



## Controller Switch Wiring – Gen 1 HW – 1 Pole Toggle Switches

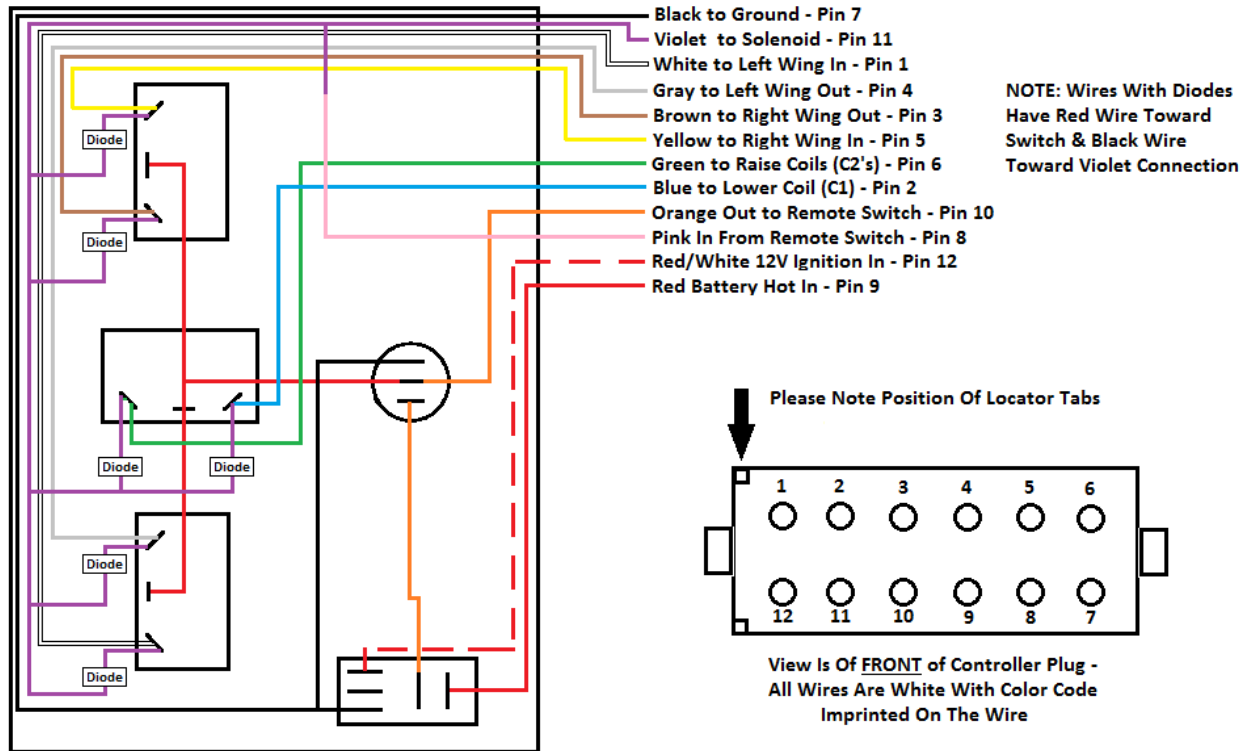

View Is Of Back Side Of Switches



## Controller Switch Wiring – Gen 1 HW – 1 Pole Rocker Switches

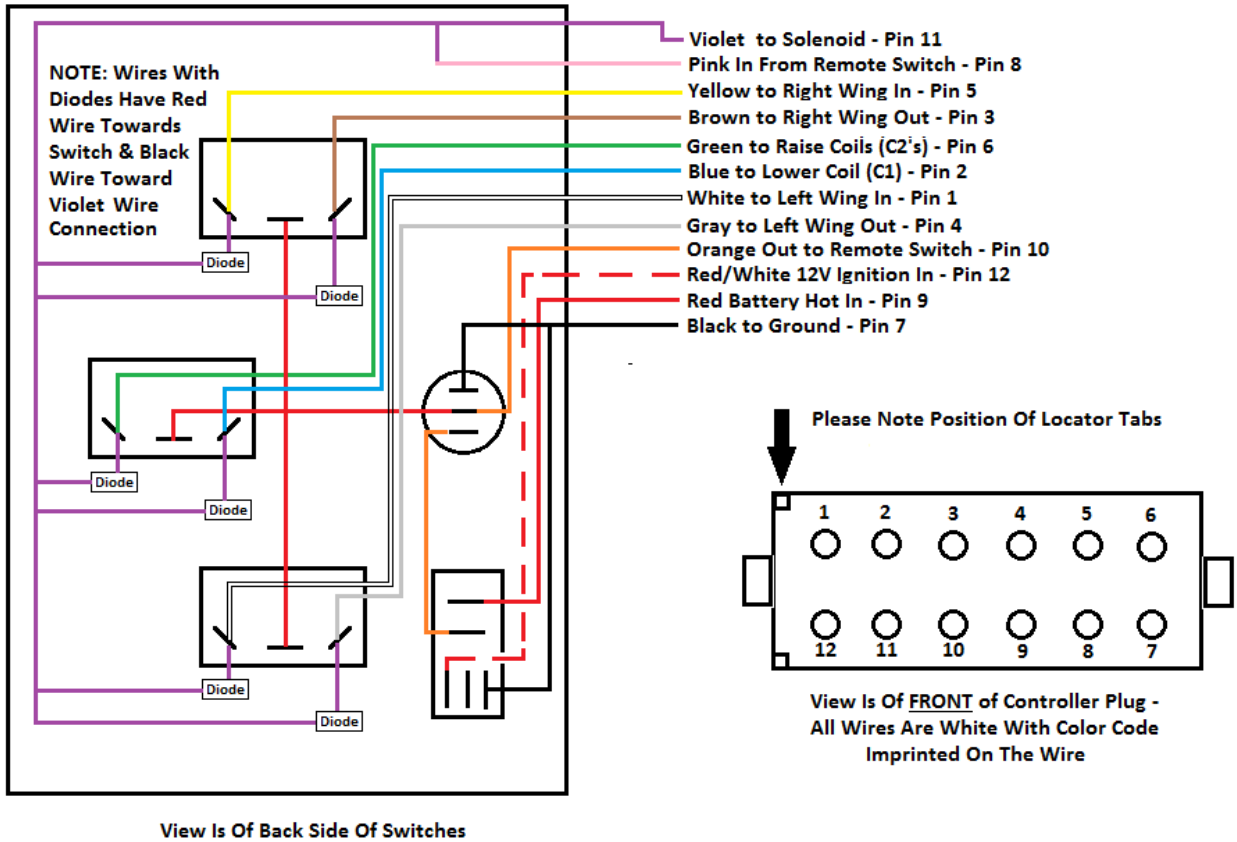



## Controller Switch Wiring – Gen 2 HW – 1 Pole Toggle Switches

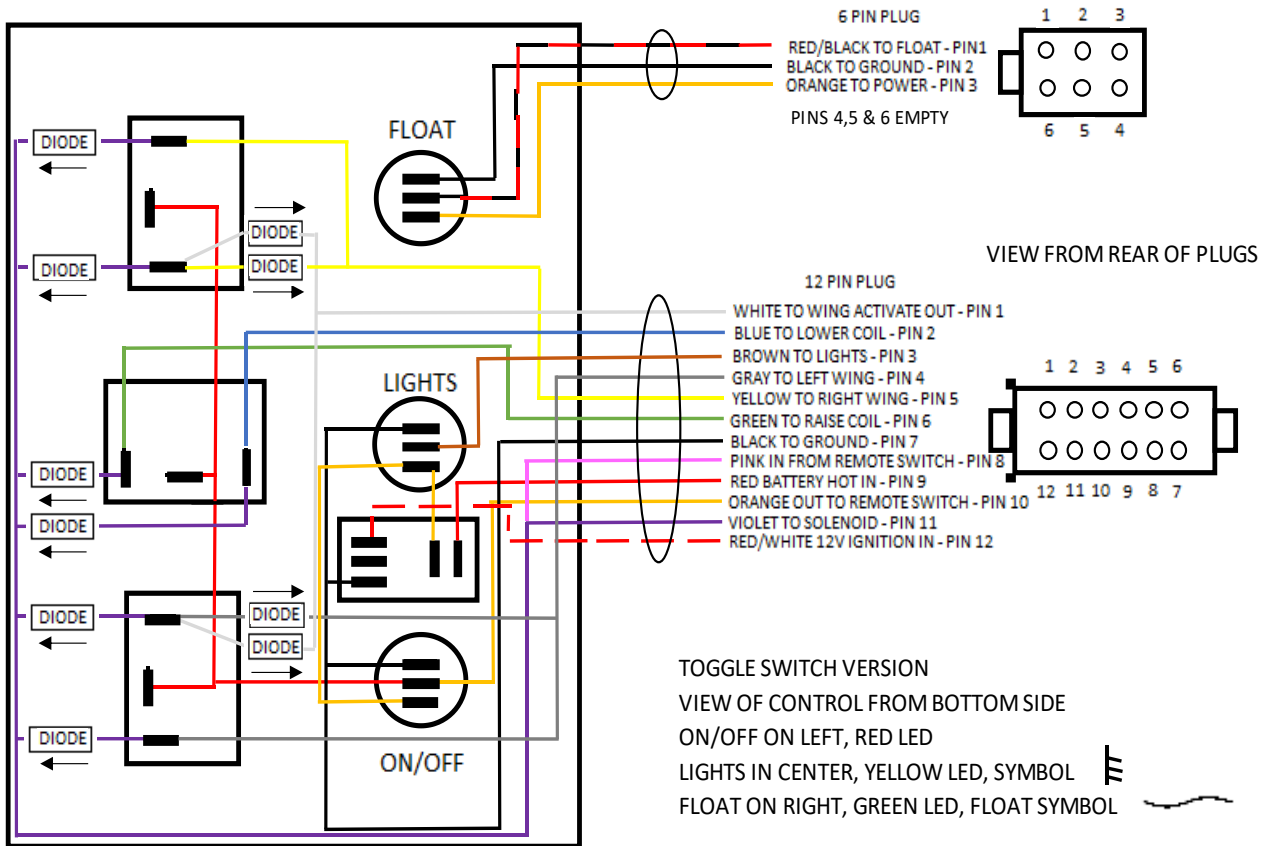



### Controller Switch Wiring – 2 Pole Toggle Fixed Wing

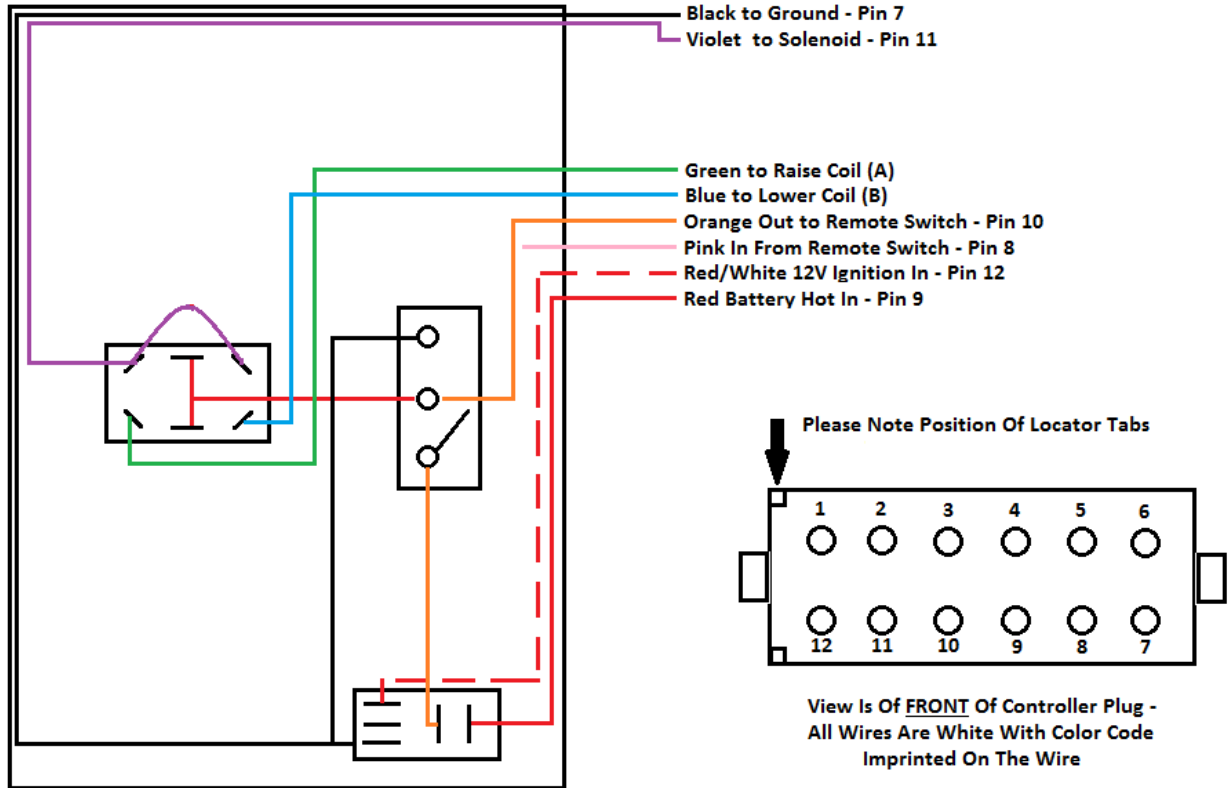



## Controller Switch Wiring – 1 Pole Toggle Fixed Wing

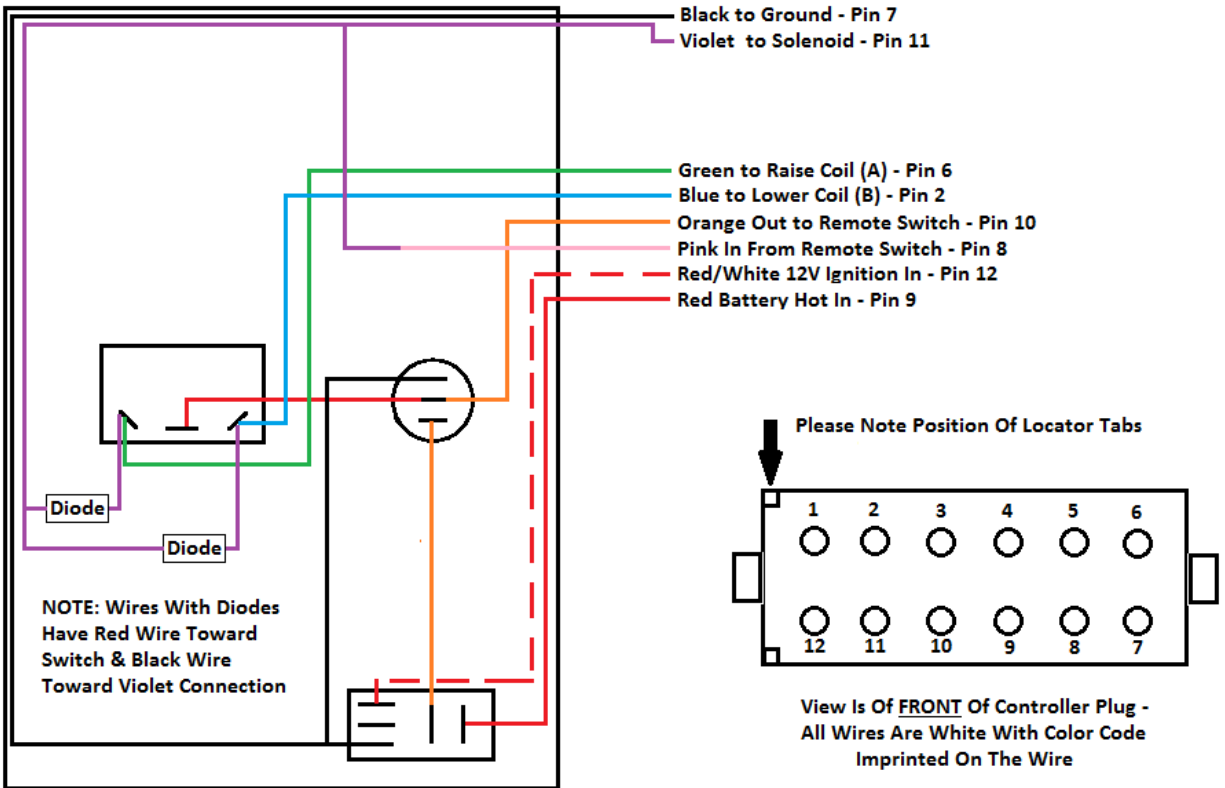



## Controller Switch Wiring – 1 Pole Rocker Fixed Wing

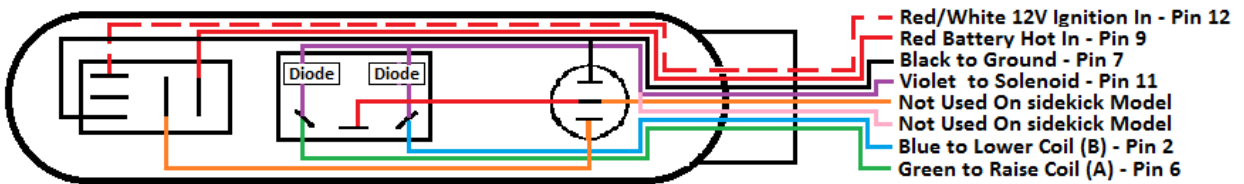

NOTE: Wires With Diodes  
Have Red Wire Toward  
Switch & Black Wire  
Toward Violet Connection

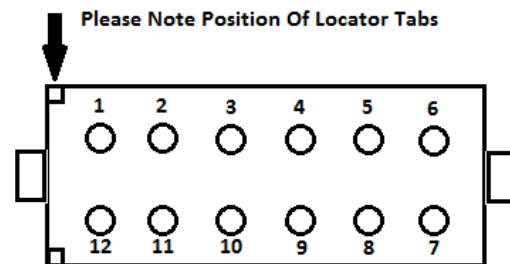

View Is Of **FRONT** Of Controller Plug -  
All Wires Are White With Color Code  
Imprinted On The Wire



## sidekick Hydraulic Schematic

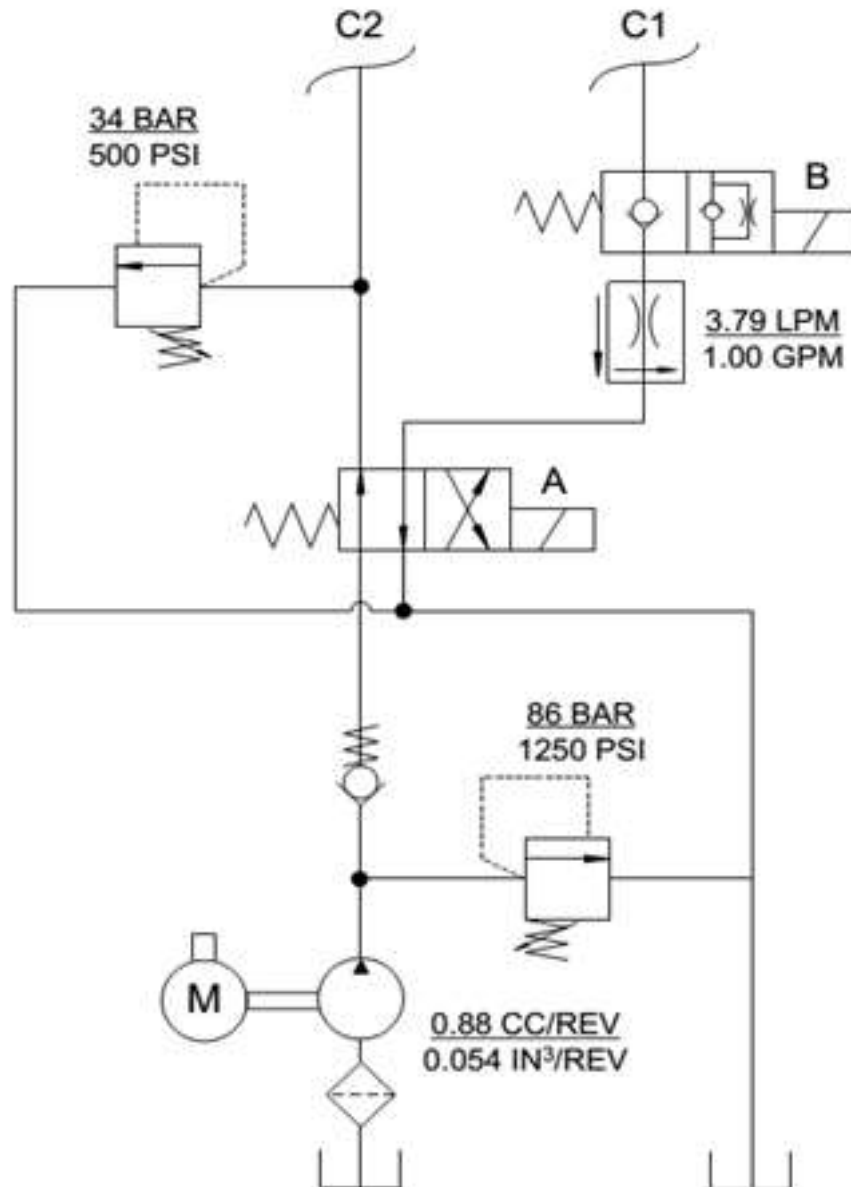

See Fixed Wing For Flow Circuits



## Electrical Power Connections – sidekick

\* See Fixed Wing Schematic

## Electrical Pump Connections – sidekick

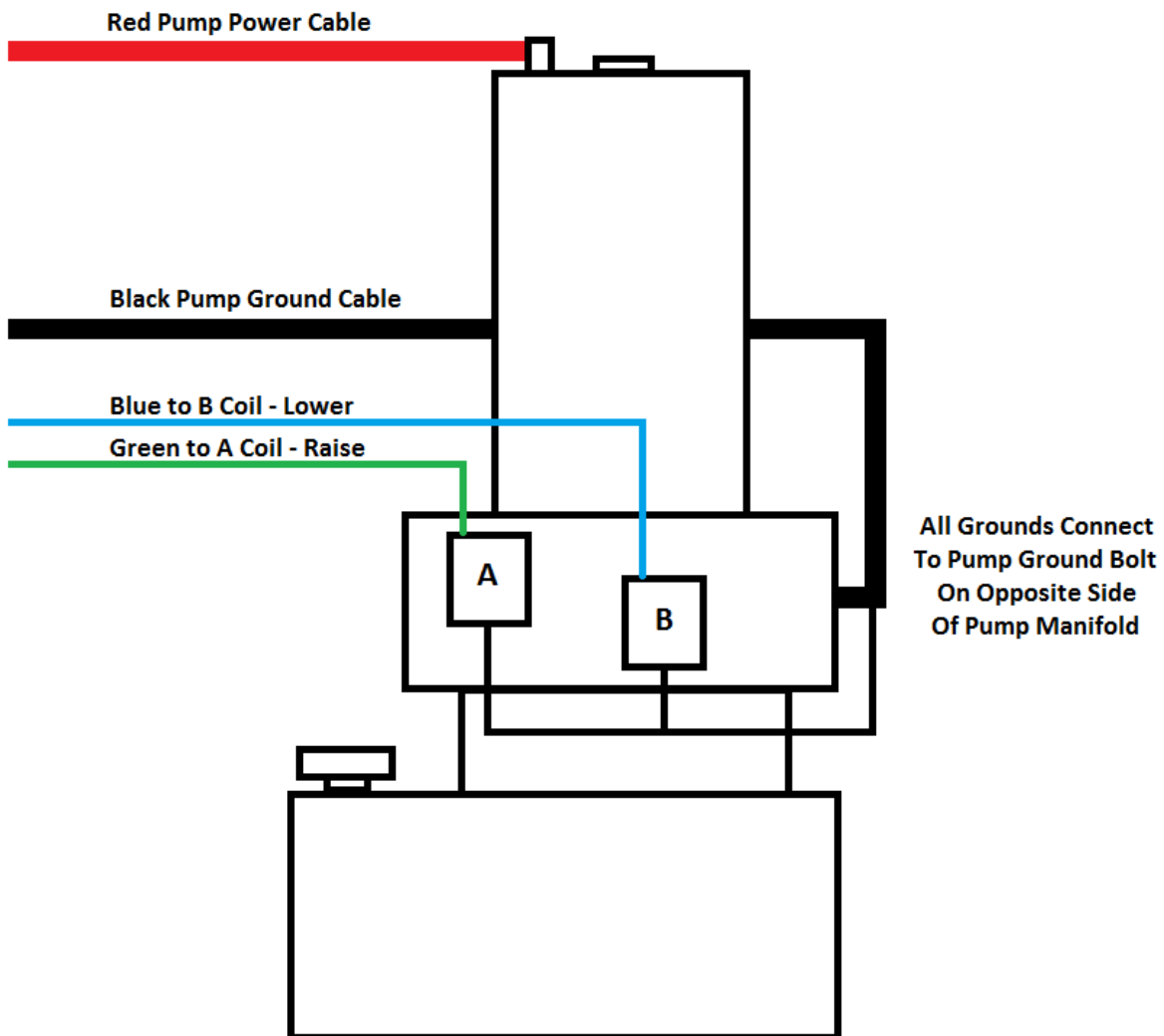



### Plow Side Hydraulic Connections – sidekick

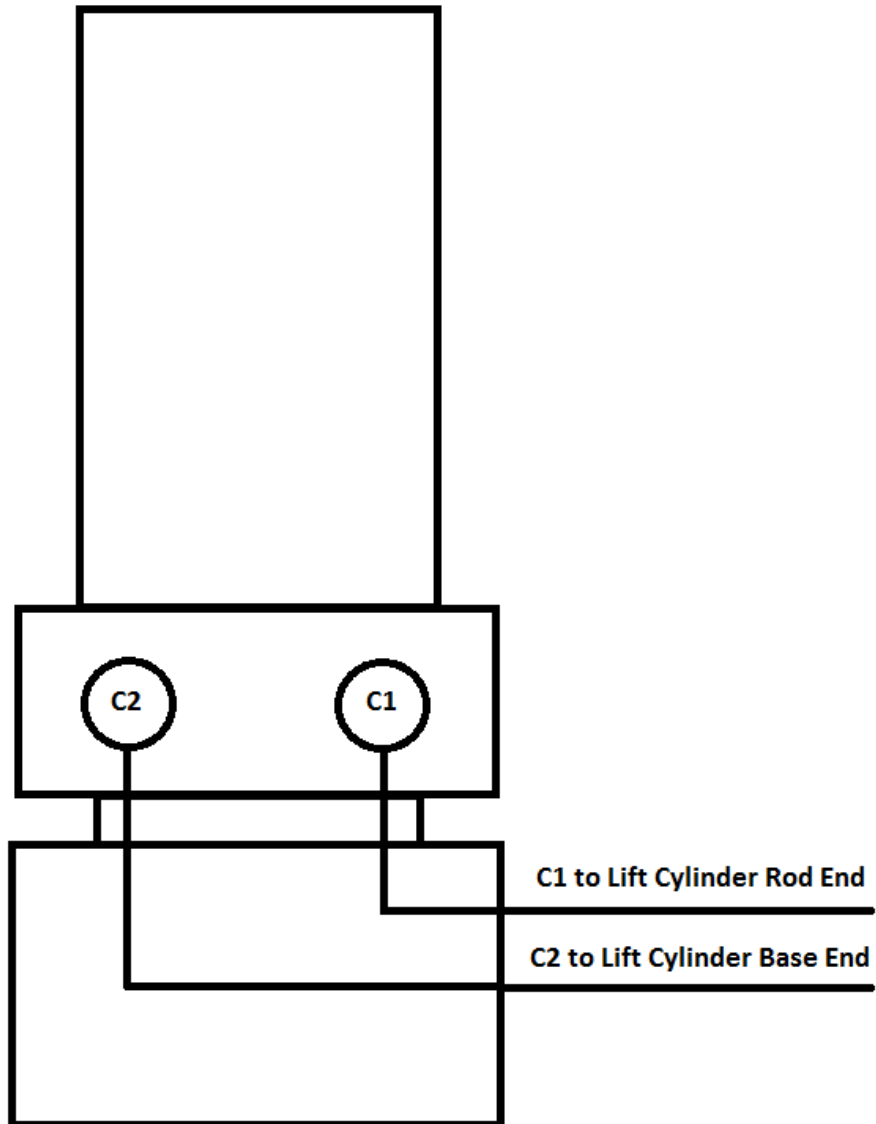



**Controller Switch Wiring – 2 Pole Toggle sidekick**

**\*See Fixed Wing**

**Controller Switch Wiring – 1 Pole Toggle sidekick**

**\*See Fixed Wing**

**Controller Switch Wiring – 1 Pole Rocker sidekick**

**\*See Fixed Wing**

**Truck Side Control Harness – sidekick**

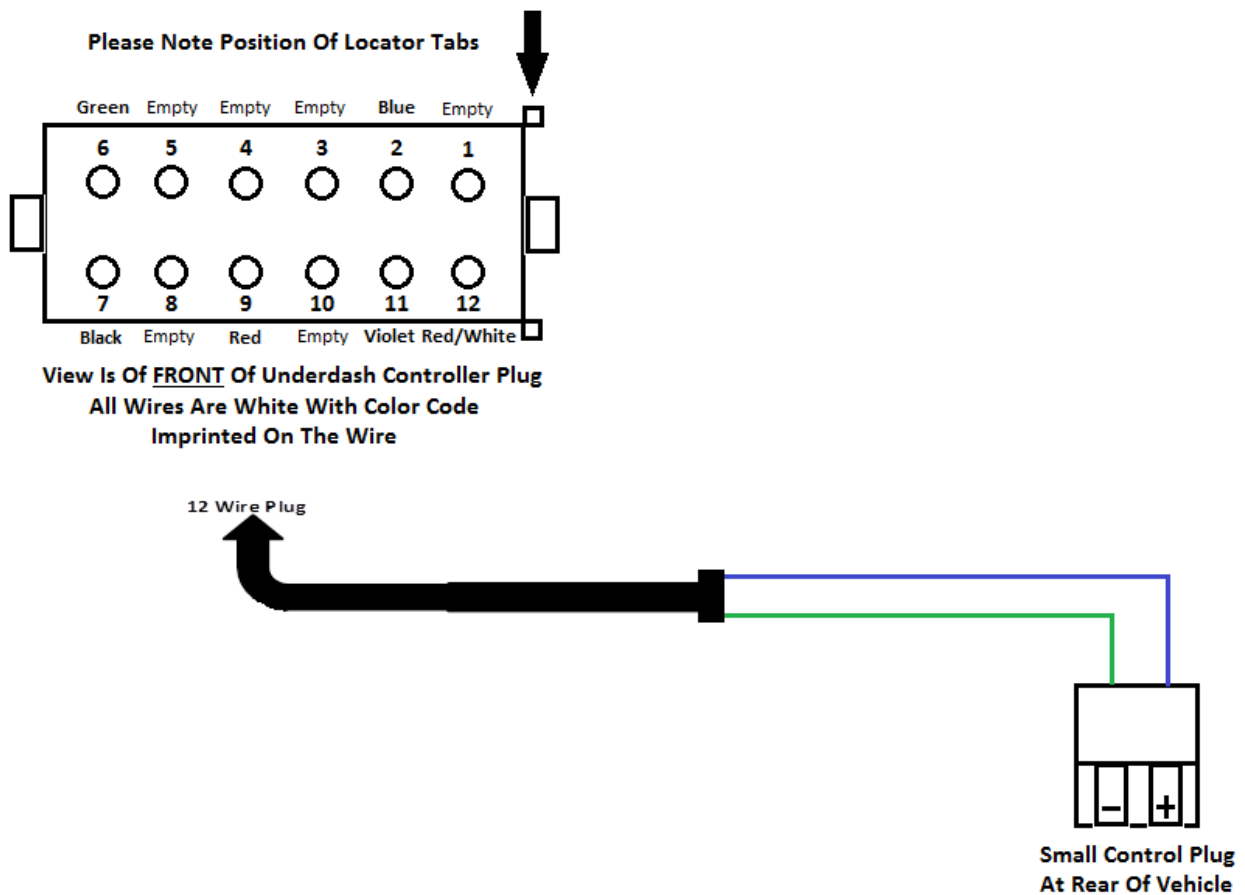



## Trouble Shooting Guides

### Common Quick Fixes

**When Installed And Maintained Properly, The Ebling Back Blade Is Extremely Reliable. The Following Are Some Examples Of Avoidable Problems We Have Come Across.**

**1- Poor Ground At Truck Frame (By Using A Long Set Of Jumper Cables Connect Battery Ground Directly To Pump Ground, This Will Tell You Immediately If The Ground Is Bad)**

**\*Grind Frame to Bare Steel, Re-Connect**

**\*Connect Directly To Frame, Do Not Connect To Crossmember, Mount Or Any Component That Is "Not Frame"**

**2- Controller Plug Not Fully Seated (Clicked In)**

**3- Controller Plug Pin(s) Not Fully Seated (Clicked In)**

**4- Rear Power Plug Terminal(s) Not Fully Seated (Clicked In)**

**5- Circuit Breaker Tripped (Or Damaged By Heat)**

**6- Bad Switch, Keep A Testing Controller On Hand To Plug In, This Is An Easy And Quick Way To Diagnose For a Bad Switch.**

**7- Plow Is Connected To Secondary Battery With Low Charge, Must Be Connected To Primary Battery**



## Hydraulic & Fixed Wing Troubleshooting Guide

<u>Problem</u>	<u>Steps to take</u>
Pump will not run, solenoid clicks	<ul style="list-style-type: none"> <li>* Circuit breaker tripped?</li> <li>* Is power crossing solenoid posts when activated?</li> <li>* Check to see if power is at power plug when activated, making sure plug terminals are fully seated in housing.</li> <li>* Check ground at rear of truck frame.</li> <li>* Check if power is reaching pump motor.</li> <li>* Pump ground hooked up?</li> <li>* Hooked to primary battery? Charge level?</li> </ul>
Pump will not run, solenoid does not click	<ul style="list-style-type: none"> <li>* Is controller on? Plugged in tight?</li> <li>* Is controller fuse/power source good?</li> <li>* Is solenoid getting signal on violet wire?</li> <li>* Is solenoid grounded?</li> </ul>
Pump runs, no movement on any functions	<ul style="list-style-type: none"> <li>* Control harness plugged in?</li> <li>* Control harness damaged?</li> <li>* Coil ground harness attached at pump ground?</li> </ul>
Pump runs, no movement on certain function	<ul style="list-style-type: none"> <li>* Is coil magnetizing?</li> <li>* Is signal reaching coil?</li> <li>* Is signal reaching that functions stud in control plug?</li> <li>* Control harness damaged?</li> <li>* Is valve stuck (not shifting).</li> <li>* Bad DPDT switch?</li> </ul>
Wing will open but not close or will close but not open/Blade will go up but not down or will go down but not up	<ul style="list-style-type: none"> <li>* Is coil magnetizing?</li> <li>* Is signal reaching coil?</li> <li>* Is signal reaching that functions stud in control plug?</li> <li>* Control harness damaged?</li> <li>* Is valve stuck (not shifting).</li> <li>* Is check valve damaged? (Wings only)</li> <li>* Bad DPDT switch?</li> <li>* Bad SPDT switch diode?</li> </ul>
Pump runs but functions not correct	<ul style="list-style-type: none"> <li>* Are under dash controller plug connections in correct positions?</li> <li>* Are coil wires in correct positions?</li> <li>* Are rear truck side and plow side control plug wires in correct positions?</li> </ul>



Remote switch not working	<ul style="list-style-type: none"> <li>* Is controller on?</li> <li>* Is switch plugged in?</li> <li>* Is there signal on pin 8 of the under dash controller plug when activated?</li> <li>* Switch bad? Try plugging in new switch.</li> </ul>
Pump won't shut off	<ul style="list-style-type: none"> <li>* Bad solenoid?</li> <li>* Bad remote switch? Unplug to test.</li> <li>* Stuck controller switch?</li> </ul>
Blades drifts down slowly.	<ul style="list-style-type: none"> <li>* Hose Leaking?</li> <li>* Check lift/lower valves for wear, damage or contamination.</li> <li>* Counterbalance valve contamination?</li> <li>* Counterbalance valve worn? Contact Ebling for additional repair instructions.</li> <li>* Lift cylinder packings worn?</li> </ul>
Circuit breaker trips	<ul style="list-style-type: none"> <li>* Is rear frame ground good?</li> <li>* Pump motor drawing too many amps?</li> <li>* Power harness chaffed (short) under truck?</li> <li>* Weak breaker?</li> </ul>
When stored off truck the QD drifts down slowly	<ul style="list-style-type: none"> <li>* Pump not designed to hold QD up. Must use stand when stored position.</li> </ul>
Blade lowers very fast (drops)	<ul style="list-style-type: none"> <li>* Lift cylinder hoses reversed.</li> </ul>
Excessive fluid leak from pump when blade is raised or wings opened	<ul style="list-style-type: none"> <li>* Reservoir is overfilled - Check fluid level with blade fully up and wings fully open - Drain fluid as needed.</li> </ul>
Pump runs, wings work normal but blade lifts slowly	<ul style="list-style-type: none"> <li>* Motor weak or loose connections?</li> <li>* Bad/weak ground on frame?</li> <li>* Check lift/lower valves for wear, damage or contamination.</li> <li>* Contact Ebling for additional repair instructions.</li> </ul>
Wing cutting edges wearing on tips	<ul style="list-style-type: none"> <li>* Check for damage to wing or moldboard</li> <li>* Adjust upper linkage arms.</li> </ul>
Wings not closing to 90 degrees	<ul style="list-style-type: none"> <li>* Check for damage to wing or moldboard</li> <li>* Shear bolt partially sheared/bent?</li> <li>* Cylinder out of adjustment?</li> </ul>
Moldboard not level to truck	<ul style="list-style-type: none"> <li>* Check for damage to moldboard/linkage arms</li> <li>* Are spring bar bolts tight?</li> <li>* Is spring bar damaged/twisted?</li> <li>* Truck frame damaged?</li> </ul>



QD arms not correct width	<ul style="list-style-type: none"><li>* Check mount/arm guide for correct spacer plates/width for the application.</li><li>* Does QD have single or double hex plates welded in each side?</li><li>* If double, refer to mount/arm guide.</li></ul>
---------------------------	---

Contact us for further instructions at:  
616-532-8400 Parts Dept. or  
[parts@eblingsnowplows.com](mailto:parts@eblingsnowplows.com)



## sidekick Troubleshooting Guide

<u>Problem</u>	<u>Steps to take</u>
Pump will not run, solenoid clicks	<ul style="list-style-type: none"> <li>* Circuit breaker tripped?</li> <li>* Is power crossing solenoid posts when activated?</li> <li>* Check to see if power is at power plug when activated, making sure plug terminals are fully seated in housing.</li> <li>* Check ground at rear of truck frame.</li> <li>* Check if power is reaching pump motor.</li> <li>* Pump ground hooked up?</li> <li>* Hooked to primary battery? Charge level?</li> </ul>
Pump will not run, solenoid does not click	<ul style="list-style-type: none"> <li>* Is controller on? Plugged in?</li> <li>* Is controller fuse/power source good?</li> <li>* Is solenoid getting signal on violet wire?</li> <li>* Is solenoid grounded?</li> </ul>
Pump runs, no movement on any function	<ul style="list-style-type: none"> <li>* Control harness plugged in?</li> <li>* Control harness damaged?</li> <li>* Coil ground harness attached at pump ground?</li> </ul>
Pump runs, no movement on certain function	<ul style="list-style-type: none"> <li>* Is coil magnetizing?</li> <li>* Is signal reaching coil?</li> <li>* Is signal reaching that functions stud in control plug?</li> <li>* Control harness damaged?</li> <li>* Is valve stuck (not shifting).</li> <li>* Bad DPDT switch?</li> <li>* Bad SPDT switch Diode?</li> </ul>
Pump runs but functions not correct	<ul style="list-style-type: none"> <li>* Are under dash controller plug connections in correct positions?</li> <li>* Are coil wires in correct positions?</li> <li>* Are rear truck side and plow side control plug wires in correct positions?</li> </ul>
Pump won't shut off	<ul style="list-style-type: none"> <li>* Bad solenoid?</li> <li>* Stuck controller switch?</li> </ul>
Blades drifts down slowly.	<ul style="list-style-type: none"> <li>* Hose Leaking?</li> <li>* Check lift/lower valves for wear, damage or contamination.</li> <li>* Lift cylinder packings worn?</li> </ul>
Circuit breaker trips	<ul style="list-style-type: none"> <li>* Is rear frame ground good?</li> <li>* Pump motor drawing too many amps?</li> <li>* Power harness chaffed (short) under truck?</li> <li>* Weak breaker?</li> </ul>



When stored off truck the crosstube drifts down slowly	* Pump not designed to hold crosstube up. Must use stand when stored position.
Blade lowers very fast (drops)	* Lift cylinder hoses reversed.
Excessive fluid leak from pump when blade is raised	* Reservoir is overfilled - Check fluid level with blade fully up. Drain fluid as needed.
Pump runs but blade lifts slowly	* Motor weak or loose connections? * Bad/weak ground on frame? * Check lift/lower valves for wear, damage or contamination. * Contact Ebling for additional repair instructions.
Moldboard not level to truck	* Check for damage to moldboard/linkage arms. * Check ratchet straps. * Truck frame/hitch damaged?

Contact us for further instructions at:  
616-532-8400 Parts Dept. or  
parts@eblingsnowplows.com



## Tractor Troubleshooting Guide

<u>Problem</u>	<u>Steps to take</u>
Wing cutting edges wearing on tips	<ul style="list-style-type: none"><li>* Check for damage to wings, moldboard or 3-point mount</li><li>* Adjust tractor top link</li></ul>
Wings not closing to 90 degrees	<ul style="list-style-type: none"><li>* Check for damage to wings, moldboard or 3-point mount</li><li>* Shear bolt partially sheared/bent?</li><li>* Cylinder out of adjustment?</li></ul>
Moldboard not level to tractor/off to one side.	<ul style="list-style-type: none"><li>* Check for damage to moldboard or 3-point mount</li><li>* Check tractor lift arms settings</li></ul>
Wings not responding to tractor controls	<ul style="list-style-type: none"><li>* Check hose connections</li><li>* Check in-line flow restrictors (1.5 &amp; 2.0) at tractor valve ports</li></ul>
Wing movements reversed	<ul style="list-style-type: none"><li>* Check hose connections</li></ul>



## **Ebling Back Blade Remote Switch Wiring** **2013 & Later Remote Switch To 2012 & Prior Truck Wiring**

### **Step 1 –**

When Replacing Remote Switches In a 2012 & Prior Wiring Harness, It Is Best To Use The New Style Remote Switch Which Is Sealed.

### **Step 2 –**

Remove The Recessed Switch Plate And Disconnect The Old Switch.

### **Step 3 –**

Take The New Style Replacement Switch, Cut Off The Deutsch Plug And Butt Connect The Wires In The Following Configuration.

<u>New Switch</u>		<u>Old Harness</u>
Orange	—————>	Green
Red	—————>	White
Green	—————>	Yellow
Blue	—————>	Brown

### **Step 4 –**

Connect The New Switch To The Recessed Switch Plate And Remount It.



## Ebling Back Blade 2012 & Prior Truck Side Wiring To 2013 & Later Vertical Pump

### **Step 1 –**

Turn Off Circuit Breaker Before Beginning.

### **Step 2 –**

You Will Need To Mount A New Solenoid To The Side Of Pump Motor Using A 5" Screw Clamp. Make Sure the Solenoid Is Positioned So The Cover Will Fit Properly (Making Sure Terminals Will Not Contact Cover At Any Time).

### **Step 3 –**

Remove The Power Cable From The Motor Stud and Reconnect It To One Of The Large Studs On The Solenoid. Now You Will Need To Make A 1/0 Cable To Connect Between The Motor Stud And The Empty Large Stud Of The Solenoid. (Must Be At Least 1/0 Battery Cable Or Damage To Motor May Occur)

### **Step 4 –**

You Will Now Need To Add 1 Wire To The Control Cord. The Wire Will Run From The Solenoids Small Terminal (Either One) To The 7-Way Plug. The 2<sup>nd</sup> Small Terminal On The Solenoid Will Need To Be Grounded To The Pump Ground.

### **Step 5 –**

Now Re-wire The Plug To The Following Configuration. View From Back Of Plug.

Position 1 – New Wire That Was Added

Position 2 – Blue

Position 3 – Green - 2 Wires

Position 4 – White

Position 5 – Gray

Position 6 – Brown

Position 7 – Yellow

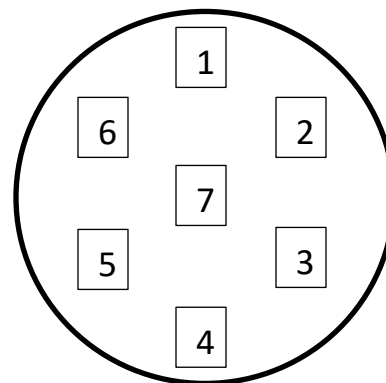



**Step 6 –**

The Red And Gray Power Plugs Are Not Compatible, You Will Need To Change One Of Them To Match. Reassemble Plug And Reconnect To Truck. Reset Circuit Breaker From Step 1.



## **Ebling Back Blade 2013 & Newer Truck Side Wiring** **To 2012 & Prior Horizontal Pump**

### **Step 1 –**

Turn Off Circuit Breaker Before Beginning.

### **Step 2 –**

You Will Need To Remove The Solenoid From The Horizontal Pump And Connect The Power Cable Directly To The Motor Stud. The Small Green Wire On The Solenoid Will Not Be Used And Can Be Blunt Cut.

### **Step 3 –**

Disconnect The 7-way Plug And Re-wire The Pump Side Plug To The Following Configuration. View Is From Back Of Plug. Reassemble Plug And Reconnect To Truck.

Position 1 – Blue

Position 2 – White

Position 3 – Red

Position 4 – Brown

Position 5 – Yellow

Position 6 – Black

Position 7 – OPEN

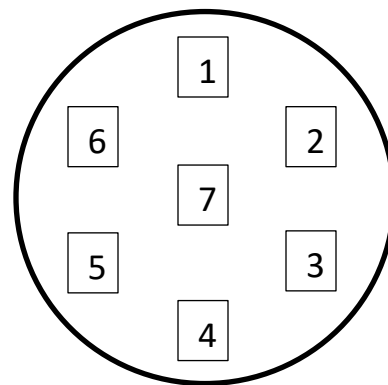

### **Step 4 –**

The Gray And Red Power Connector Plugs Are Not Compatible. Change The Gray Plug On The Pump Side To A New Style Red Plug.

### **Step 5 –**

Reset The Circuit Breaker.



## **Ebling Back Blade Toggle Switch Wiring** **Re-Wire DPDT (Double Pole Double Throw) Switch Controller** **To Accept SPDT (Single Pole Double Throw) Switch**

In order for a SPDT toggle switch to work in place of a DPDT toggle switch, diodes must be added to the solenoid activation leads inside the control box as follows –

Parts needed-

Qty 1 – SPDT Toggle Switch Conversion Kit / E&S # AA01- 0079



1. Unplug controller and remove the top to gain access to the switches.
2. Remove the wires from the switch connections on the DPDT switch(es) to be changed and remove switch(es).
3. Add diodes to the solenoid activation wire so as to let signal travel from the switch out. Diodes block any signal from flowing into a switch connection, if these are installed in the wrong direction the plow will not operate correctly. (See illustration #1)
4. Install new SPDT switch(es) into control top and install wires to the correct positions. (See illustration #1) \*NOTE - If you are changing the left wing switch you will also need to relocate the pink wire for the remote switch (see illustration #2).
5. Reassemble control box top, plug in controller and test plow functions.



# Illustration #1

## Raise/Lower Switch Sample

Remove Violet  
Jumper Wire  
& Terminals

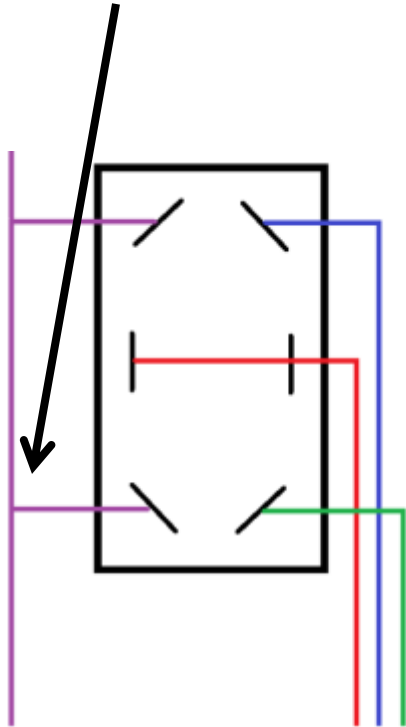

Old DPDT Switch

Butt Connect  
Diodes To The  
2 Remaining  
Violet Wires

Connect Red  
Side Of Diodes  
To Screw Tab  
With Coil Wires

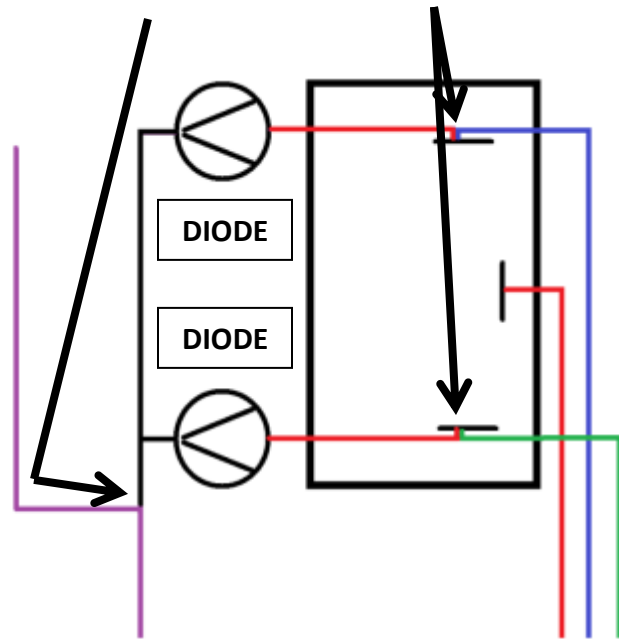

New SPDT Switch

**Violet – Solenoid Activation**

**Red – Power In**

**Blue – Lower**

**Green – Raise**

\*Note That Diodes Have A Red Wire On One Side And A Black Wire On The Other To Distinguish Flow Direction.

\*Refer To Controller Schematic In Manual For All Wire Colors & Functions For Other Switches.



## Illustration #2

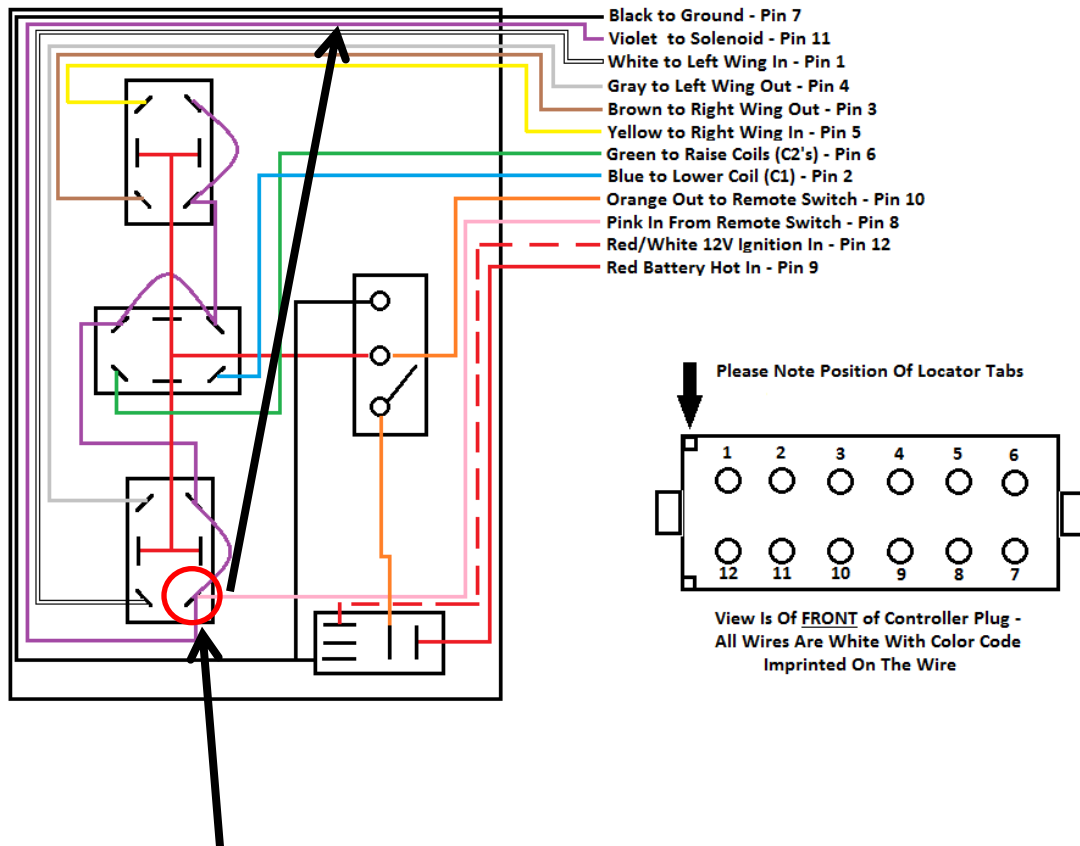

If the left wing switch is changed, you will need to also disconnect the pink wire shown and connect it to the violet wire between ANY diodes and the controller plug.

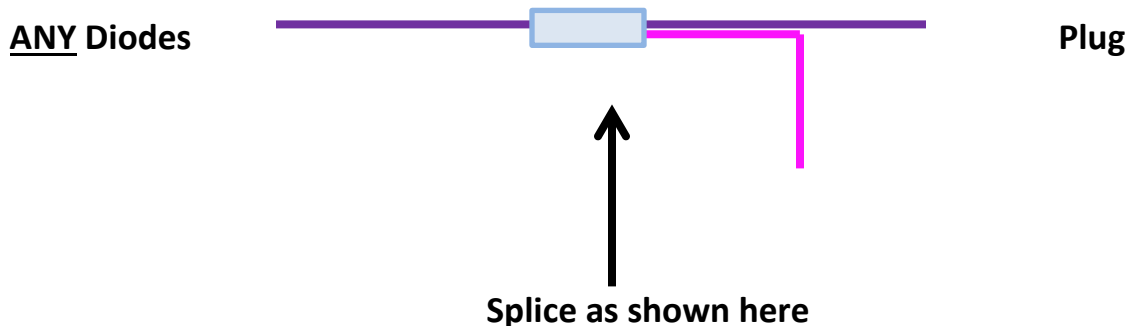



# CAUTION !

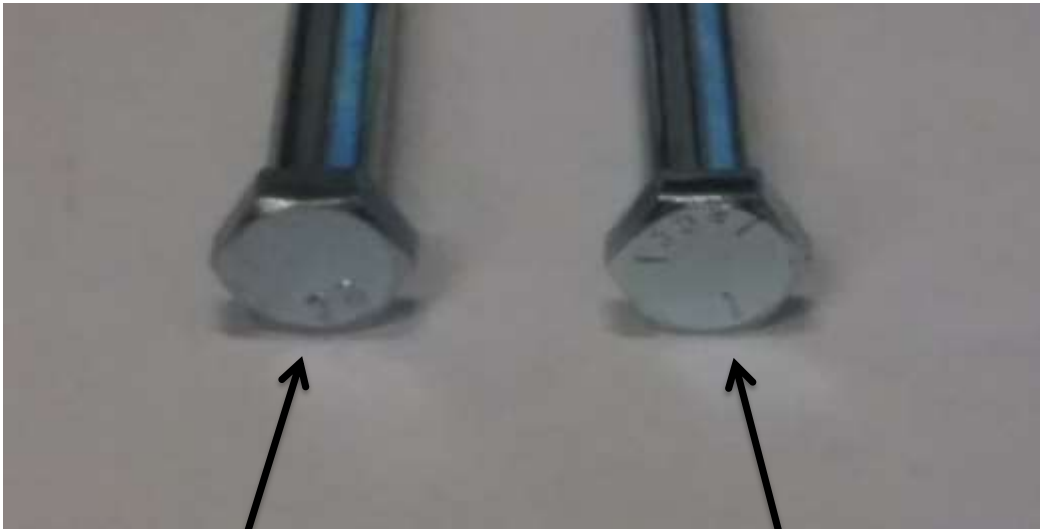

No Hash Marks  
Grade 2

3 Hash Marks  
Grade 5

**When Servicing Or Inspecting A Customers Back Blade Always  
Take Time To Check Shear Bolts, Drivers Have Been Known To  
Use Whatever They Have Available To Keep Plowing  
After A Bolt Has Sheared**

**Grade 2 Bolts Must Be Used For All Shear Bolts  
Damage Will Occur If A Higher Grade Bolt Is Used**



# CAUTION!

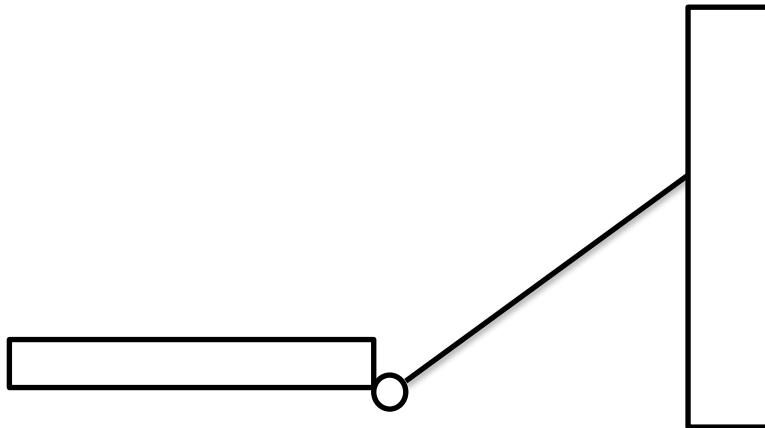

**DO NOT plow against curbing with wing partially open**

**Damage to hinge knuckles and cylinder will occur not covered by warranty!**

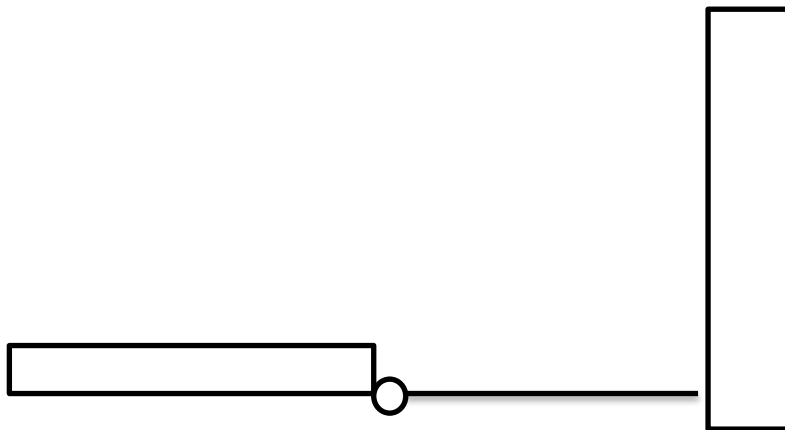

**Plowing against curbing is not recommended, if you do make sure wing is fully open in order for the shear bolt to work as designed if an obstruction is hit.**



## **Contact Information**

### **Home Office & Sales -**

**Ebling Snowplows**

**4500 Roger B Chaffee Dr SE**

**Kentwood, MI 49548**

**616.532.8400**

### **Technical & Parts Phone -**

**616.532.8400/Parts**

### **Technical & Parts E-mail -**

**[john@eblingsnowplows.com](mailto:john@eblingsnowplows.com)**

### **All Mount Instructions, Drawings & Manuals On Line -**

**[eblingandson.com /support](http://eblingandson.com/support)**



## Installation Checklists

These installation check lists are used every time a new or used BACK BLADE is installed at Ebling Snowplows. By using these you can keep a record for future reference and also catch any possible problems with the installation **before** the plow is given to the customer. We encourage dealers to make use of them.



## TRUCK HYDRAULIC WING BACK BLADE INSTALLATION CHECKLIST

Customer \_\_\_\_\_

Assembly Date \_\_\_\_\_

Plow Model \_\_\_\_\_

Installation Date \_\_\_\_\_

### Mechanical Assembly

- Moldboard & wing size matches customer order (plow is dimensionally correct for order)
- Moldboard & wing cutting edges correct per order (steel vs. poly)
- Wings checked and set at 90° with jam nuts tightened against adjustable end
- Shear bolt size \_\_\_\_\_
- All fasteners present, oriented correctly, and tightened properly
- All clevis pins correct size, greased, and cotter pins installed properly
- Plow aligned properly to truck, spring bar and upper arms adjusted, jam nuts tight
- Side marker flags installed and straight
- Reflective tape correct length for moldboard & wing size, installed & positioned correctly
- All decals installed properly (*EBLING BACK BLADE*, oval logo, and American flag)
- Serial number decal installed – S/N \_\_\_\_\_
- Paint inspected and touch-up as necessary
- Plow cleaned and wiped down (showroom-ready condition)

Installed By \_\_\_\_\_ Checked By \_\_\_\_\_

### Hydraulic Assembly

- All hydraulic hoses and fittings present and plumbed correctly – Hyd.# \_\_\_\_\_
- All abrasion shields present, all hoses and abrasion shields correctly oriented
- All lines and fittings checked for leaks
- Hydraulic unit tested and functions properly
- Fluid topped off correctly

Installed By \_\_\_\_\_ Checked By \_\_\_\_\_

### Electrical Assembly

- All wiring connections checked for accuracy
- All connections fit properly
- All wiring and harnesses routed properly and tie-wrapped neatly
- Plow functional test completed and passed

Installed By \_\_\_\_\_ Checked By \_\_\_\_\_



**TRUCK FIXED WING BACK BLADE INSTALLATION CHECKLIST**

Customer \_\_\_\_\_

Assembly Date \_\_\_\_\_

Plow Model \_\_\_\_\_

Installation Date \_\_\_\_\_

**Mechanical Assembly**

- Moldboard & fixed wing size matches order (plow is dimensionally correct for order)
- Moldboard & wing cutting edges correct per order (steel vs. poly)
- All fasteners present, oriented correctly, and tightened properly
- All clevis pins correct size, greased, and cotter pins installed properly
- Plow aligned properly to truck, spring bar and upper arms adjusted, jam nuts tight
- Side marker flags installed and straight
- Reflective tape correct length for moldboard & wing size, installed & positioned correctly
- All decals installed properly (*EBLING BACK BLADE*, oval logo, and American flag)
- Serial number decal installed – S/N \_\_\_\_\_
- Paint inspected and touch-up as necessary
- Plow cleaned and wiped down (showroom-ready condition)

Installed By \_\_\_\_\_ Checked By \_\_\_\_\_

**Hydraulic Assembly**

- All hydraulic hoses and fittings present and plumbed correctly – Hyd.# \_\_\_\_\_
- All abrasion shields present, all hoses and abrasion shields correctly oriented
- All lines and fittings checked for leaks
- Hydraulic unit tested and functions properly
- Fluid topped off correctly

Installed By \_\_\_\_\_ Checked By \_\_\_\_\_

**Electrical Assembly**

- All wiring connections checked for accuracy
- All connections fit properly
- All wiring and harnesses routed properly and tie-wrapped neatly
- Plow functional test completed and passed

Installed By \_\_\_\_\_ Checked By \_\_\_\_\_



**sidekick BACK BLADE INSTALLATION CHECKLIST**

Customer \_\_\_\_\_

Assembly Date \_\_\_\_\_

Plow Model \_\_\_\_\_

Installation Date \_\_\_\_\_

**Mechanical Assembly**

- Moldboard matches order (plow is dimensionally correct for order)
- Moldboard & wing cutting edges correct per order (steel vs. poly)
- All fasteners present, oriented correctly, and tightened properly
- All clevis pins correct size, greased, and cotter pins installed properly
- Plow aligned properly to truck, upper arms adjusted and bolts tight
- Side marker flags installed and straight
- Reflective tape installed & positioned correctly
- All decals installed properly (*sidekick*, oval logo, and American flag)
- Serial number decal installed – S/N \_\_\_\_\_
- Paint inspected and touch-up as necessary
- Plow cleaned and wiped down (showroom-ready condition)

Installed By \_\_\_\_\_ Checked By \_\_\_\_\_

**Hydraulic Assembly**

- All hydraulic hoses and fittings present and plumbed correctly – Hyd.# \_\_\_\_\_
- All hoses correctly oriented
- All lines and fittings checked for leaks
- Hydraulic unit tested and functions properly

Installed By \_\_\_\_\_ Checked By \_\_\_\_\_

**Electrical Assembly**

- All wiring connections checked for accuracy
- All connections fit properly
- All wiring and harnesses routed properly and tie-wrapped neatly
- Plow functional test completed and passed

Installed By \_\_\_\_\_ Checked By \_\_\_\_\_



## TRACTOR BACK BLADE INSTALLATION CHECKLIST

Customer \_\_\_\_\_

Assembly Date \_\_\_\_\_

Plow Model \_\_\_\_\_

Installation Date \_\_\_\_\_

### Mechanical Assembly

- Moldboard & wing size matches customer order (plow is dimensionally correct for order)
- Moldboard & wing cutting edges correct per order (steel vs. poly)
- Wings checked and set at 90° with jam nuts tightened against adjustable end
- Shear bolt size \_\_\_\_\_
- All fasteners present, oriented correctly, and tightened properly
- All clevis pins correct size, greased, and cotter pins installed properly
- Mount installed correctly and leveled/aligned on tractor 3-point arms
- Side marker flags installed and straight
- Reflective tape correct length for moldboard & wing size, installed & positioned correctly
- All decals installed properly (*EBLING BACK BLADE*, oval logo, and American flag)
- Serial number decal installed – S/N \_\_\_\_\_
- Paint inspected and touch-up as necessary
- Plow cleaned and wiped down (showroom-ready condition)

Installed By \_\_\_\_\_ Checked By \_\_\_\_\_

### Hydraulic Assembly

- All hydraulic hoses & fittings present, hoses correct length, and plumbed correctly
- All abrasion shields present, all hoses and abrasion shields correctly oriented
- All lines and fittings checked for leaks
- Plow function tested and functions properly

Installed By \_\_\_\_\_ Checked By \_\_\_\_\_